

С

ТСGG, TDM, TGM

Технические характеристики

По вопросам продаж и поддержки обращайтесь:

Алматы (7273)495-231
Ангарск (3955)60-70-56
Архангельск (8182)63-90-72
Астрахань (8512)99-46-04
Барнаул (3852)73-04-60
Белгород (4722)40-23-64
Благовещенск (4162)22-76-07
Брянск (4832)59-03-52
Владивосток (423)249-28-31
Владикавказ (8672)28-90-48
Владимир (4922)49-43-18
Волгоград (844)278-03-48
Вологда (8172)26-41-59
Воронеж (473)204-51-73
Екатеринбург (343)384-55-89
Иваново (4932)77-34-06
Ижевск (3412)26-03-58
Иркутск (395)279-98-46
Казань (843)206-01-48
Россия +7(495)268-04-70

Калининград (4012)72-03-81
Калуга (4842)92-23-67
Кемерово (3842)65-04-62
Киров (8332)68-02-04
Коломна (4966)23-41-49
Кострома (4942)77-07-48
Краснодар (861)203-40-90
Красноярск (391)204-63-61
Курск (4712)77-13-04
Курган (3522)50-90-47
Липецк (4742)52-20-81
Магнитогорск (3519)55-03-13
Москва (495)268-04-70
Мурманск (8152)59-64-93
Набережные Челны (8552)20-53-41
Нижний Новгород (831)429-08-12
Новокузнецк (3843)20-46-81
Ноябрьск (3496)41-32-12
Новосибирск (383)227-86-73
Киргизия +996(312)-96-26-47

Омск (3812)21-46-40
Орел (4862)44-53-42
Оренбург (3532)37-68-04
Пенза (8412)22-31-16
Петрозаводск (8142)55-98-37
Псков (8112)59-10-37
Пермь (342)205-81-47
Ростов-на-Дону (863)308-18-15
Рязань (4912)46-61-64
Самара (846)206-03-16
Саранск (8342)22-96-24
Санкт-Петербург (812)309-46-40
Саратов (845)249-38-78
Севастополь (8692)22-31-93
Симферополь (3652)67-13-56
Смоленск (4812)29-41-54
Сочи (862)225-72-31
Ставрополь (8652)20-65-13
Сургут (3462)77-98-35
Казахстан +7(7172)727-132

Сыктывкар (8212)25-95-17
Тамбов (4752)50-40-97
Тверь (4822)63-31-35
Тольятти (8482)63-91-07
Томск (3822)98-41-53
Тула (4872)33-79-87
Тюмень (3452)66-21-18
Ульяновск (8422)24-23-59
Улан-Удэ (3012)59-97-51
Уфа (347)229-48-12
Хабаровск (4212)92-98-04
Чебоксары (8352)28-53-07
Челябинск (351)202-03-61
Череповец (8202)49-02-64
Чита (3022)38-34-83
Якутск (4112)23-90-97
Ярославль (4852)69-52-93

Model:
TCGG-36-HC-LD

Display Case:

Curved Glass Refrigerated Deli Case with Hydrocarbon Refrigerant and LED Lighting



TCGG-36-HC-LD

- ▶ True's curved glass deli case combines efficient, high volume merchandising and exceptional refrigeration with an elegant curved glass front for sophisticated presentation of deli products.
- ▶ High humidity gravity coil refrigeration system maintains 38°F to 40°F (3.3°C to 4.4°C) for the freshest display of meats, cheeses and deli products.
- ▶ Factory engineered, self-contained, capillary tube system using environmentally friendly R290 hydrocarbon refrigerant that has zero (0) ozone depletion potential (ODP), & three (3) global warming potential (GWP).
- ▶ Cabinet is NSF/ANSI Standard 7 certified to hold open food product.
- ▶ Insulated double panel curved front glass provides maximum insulation value for greater efficiency and energy savings. Both panes are tempered for safety.
- ▶ Two (2) adjustable, lighted, cantilevered PVC coated shelves.
- ▶ LED lights are low UV emitting to enhance product appearance and increase shelf life.
- ▶ Exterior - durable and permanent no peel or chip white powder coated cold rolled steel with stainless steel top and trim.
- ▶ Interior - White aluminum sides and top with stainless steel floor.

ROUGH-IN DATA

Chart dimensions rounded up to the nearest 1/8" (millimeters rounded up to next whole number). Specifications subject to change without notice.

Model	Doors	Shelves	Cabinet Dimensions (inches) (mm)			HP	Voltage	Amps	NEMA Config.	Cord Length (total ft.) (total m)	Crated Weight (lbs.) (kg)
			W	D†	H						
TCGG-36-HC-LD	2	2	36¼ 921	35¼ 896	47¾ 1213	1/3 N/A	115/60/1	3.3 N/A	5-15P	9 2.74	400 182

† Depth does not include 7/8" (23 mm) for door handles.

Model:
TCGG-36-HC-LD

Display Case: Curved Glass Refrigerated Deli Case with Hydrocarbon Refrigerant and LED Lighting



STANDARD FEATURES

DESIGN

- True's curved glass deli display case combines efficient, high volume merchandising and exceptional refrigeration with an elegant curved glass front for sophisticated presentation of deli products.
- Gravity coil refrigeration system guarantees the freshest display of meats, cheeses and deli products.

REFRIGERATION SYSTEM

- Factory engineered, self-contained, capillary tube system using environmentally friendly R290 hydrocarbon refrigerant that has zero (0) ozone depletion potential (ODP), & three (3) global warming potential (GWP).
- Extra large evaporator coil balanced with higher horsepower compressor and large condenser maintains 38°F to 40°F (3.3°C to 4.4°C).
- High humidity gravity coil refrigeration system. Ideally suited for deli meats, cheeses and salads.
- Condensing unit located behind panel in back of unit. Entire system slides out for easy cleaning and maintenance.
- Automatic defrost system; time-initiated, time-terminated.

CABINET CONSTRUCTION

- Exterior - durable and permanent no peel or chip white powder coated cold rolled steel with stainless steel top and trim.
- Interior - White aluminum sides and top with stainless steel floor.

- Insulation - entire cabinet structure is foamed-in-place using a high density, polyurethane insulation that has zero ozone depletion potential (ODP) and zero global warming potential (GWP).
- Welded, heavy duty steel frame rail, black powder coated for corrosion protection.
- Frame rail fitted with leg levelers.

CURVED FRONT DISPLAY GLASS

- Insulated double panel glass provides maximum insulation value for greater efficiency and energy savings. Both panes are tempered for safety.

REAR DOORS

- "Low-E", double pane thermal glass inserts with mitered plastic channel frames.
- Each door fitted with 12" (305 mm) long black aluminum handle.
- Self-closing doors. Sliding doors ride on stainless steel V-Channel with stainless steel bearings for smooth, even, positive closure. Doors fit within plastic channel frame.

SHELVING

- Two (2) adjustable, lighted, cantilevered white heavy duty PVC coated wire shelves 30 3/8" L x 22 1/2" D (772 mm x 572 mm). Shelving system is cantilevered with adjustable angle to maximize presentation.

LIGHTING

- Cabinet equipped with three LED (3) light sources for maximum product display; two (2) shelf mounted and one (1) cabinet mounted.

MODEL FEATURES

- Evaporator is epoxy coated to eliminate the potential of corrosion.
- Four (4) amp exterior scale receptacle.
- NSF/ANSI Standard 7 compliant for open food product.

ELECTRICAL

- Unit completely pre-wired at factory and ready for final connection to a 115/60/1 phase, 15 amp dedicated outlet. Cord and plug set included.



115/60/1
NEMA-5-15R

RECOMMENDED OPERATING CONDITIONS

- TCGG refrigerated models are designed to operate in an environment where temperature and humidity do not exceed 75°F (24°C) and 55% relative humidity.

OPTIONAL FEATURES/ACCESSORIES

Upcharge and lead times may apply.

- 6" (153 mm) standard legs.
- 6" (153 mm) seismic/flanged legs.
- 2 1/2" (64 mm) diameter castors.
- 4" (102 mm) diameter castors.
- Ratchet locks.
- Additional lighted shelf (maximum of 3 shelves per cabinet).
- Non-lighted shelves.

PLAN VIEW

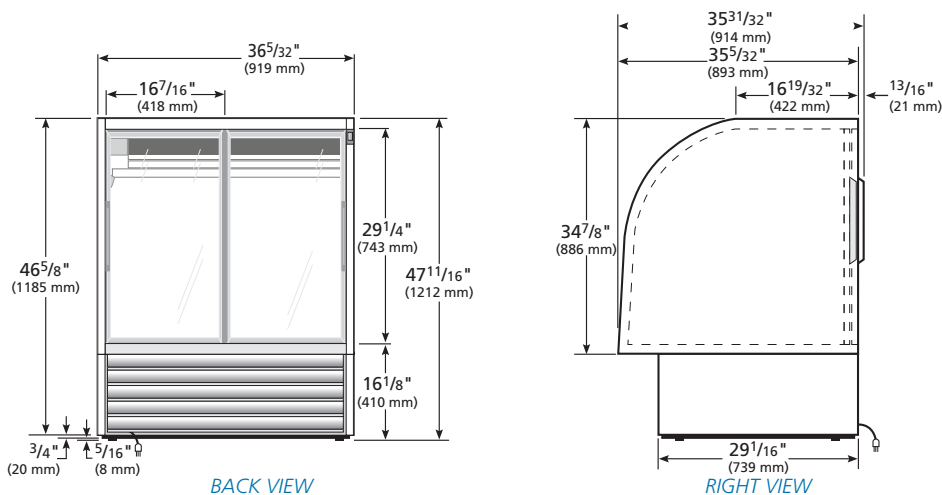

METRIC DIMENSIONS ROUNDED UP TO THE NEAREST WHOLE MILLIMETER

SPECIFICATIONS SUBJECT TO CHANGE WITHOUT NOTICE



Model	Elevation	Right	Plan	3D	Back
TCGG-36-HC-LD					

Model:
TCGG-36-S-HC-LD

Display Case:

Stainless Steel Curved Glass Refrigerated Deli Case with Hydrocarbon Refrigerant and LED Lighting



TCGG-36-S-HC-LD

- ▶ True's curved glass deli case combines efficient, high volume merchandising and exceptional refrigeration with an elegant curved glass front for sophisticated presentation of deli products.
- ▶ High humidity gravity coil refrigeration system maintains 38°F to 40°F (3.3°C to 4.4°C) for the freshest display of meats, cheeses and deli products.
- ▶ Factory engineered, self-contained, capillary tube system using environmentally friendly R290 hydrocarbon refrigerant that has zero (0) ozone depletion potential (ODP), & three (3) global warming potential (GWP).
- ▶ Cabinet is NSF/ANSI Standard 7 certified to hold open food product.
- ▶ Insulated double pane curved front glass provides maximum insulation value for greater efficiency and energy savings. Both panes are tempered for safety.
- ▶ Two (2) adjustable, lighted, cantilevered PVC coated shelves.
- ▶ LED lights are low UV emitting to enhance product appearance and increase shelf life.
- ▶ All stainless steel interior and exterior.

ROUGH-IN DATA

Chart dimensions rounded up to the nearest 1/8" (millimeters rounded up to next whole number). Specifications subject to change without notice.

Model	Doors	Shelves	Cabinet Dimensions (inches) (mm)			HP	Voltage	Amps	NEMA Config.	Cord Length (total ft.) (total m)	Crated Weight (lbs.) (kg)
			W	D†	H						
TCGG-36-S-HC-LD	2	2	36¼ 921	35¼ 896	47¾ 1213	1/3 N/A	115/60/1	3.3 N/A	5-15P	9 2.74	400 182

† Depth does not include 7/8" (23 mm) for door handles.

Model:
TCGG-36-S-HC-LD

Display Case:

*Stainless Steel Curved Glass Refrigerated Deli Case
with Hydrocarbon Refrigerant and LED Lighting*

true®

STANDARD FEATURES

DESIGN

- True's curved glass deli display case combines efficient, high volume merchandising and exceptional refrigeration with an elegant curved glass front for sophisticated presentation of deli products.
- Gravity coil refrigeration system guarantees the freshest display of meats, cheeses and deli products.

REFRIGERATION SYSTEM

- Factory engineered, self-contained, capillary tube system using environmentally friendly R290 hydrocarbon refrigerant that has zero (0) ozone depletion potential (ODP), & three (3) global warming potential (GWP).
- Extra large evaporator coil balanced with higher horsepower compressor and large condenser maintains 38°F to 40°F (3.3°C to 4.4°C).
- High humidity gravity coil refrigeration system. Ideally suited for deli meats, cheeses and salads.
- Condensing unit located behind panel in back of unit. Entire system slides out for easy cleaning and maintenance.
- Automatic defrost system; time-initiated, time-terminated.

CABINET CONSTRUCTION

- Exterior - all stainless steel front, sides, back and top.
- Interior - all stainless steel sides and floor.

- Insulation - entire cabinet structure is foamed-in-place using a high density, polyurethane insulation that has zero ozone depletion potential (ODP) and zero global warming potential (GWP).
- Welded, heavy duty steel frame rail, black powder coated for corrosion protection.
- Frame rail fitted with leg levelers.

CURVED FRONT DISPLAY GLASS

- Insulated double pane glass provides maximum insulation value for greater efficiency and energy savings. Both panes are tempered for safety.

REAR DOORS

- "Low-E", double pane thermal glass inserts with mitered plastic channel frames.
- Each door fitted with 12" (305 mm) long black aluminum handle.
- Self-closing doors. Sliding doors ride on stainless steel V-Channel with stainless steel bearings for smooth, even, positive closure. Doors fit within plastic channel frame.

SHELVING

- Two (2) adjustable, lighted, cantilevered gray heavy duty PVC coated wire shelves 30 3/8" L x 22 1/2" D (772 mm x 572 mm). Shelving system is cantilevered with adjustable angle to maximize presentation.

LIGHTING

- Cabinet equipped with three LED (3) light sources for maximum product display; two (2) shelf mounted and one (1) cabinet mounted.

MODEL FEATURES

- Evaporator is epoxy coated to eliminate the potential of corrosion.
- Four (4) amp exterior scale receptacle.
- NSF/ANSI Standard 7 compliant for open food product.

ELECTRICAL

- Unit completely pre-wired at factory and ready for final connection to a 115/60/1 phase, 15 amp dedicated outlet. Cord and plug set included.



115/60/1
NEMA-5-15R

RECOMMENDED OPERATING CONDITIONS

- TCGG refrigerated models are designed to operate in an environment where temperature and humidity do not exceed 75°F (24°C) and 55% relative humidity.

OPTIONAL FEATURES/ACCESSORIES

Upcharge and lead times may apply.

- 6" (153 mm) standard legs.
- 6" (153 mm) seismic/flanged legs.
- 2 1/2" (64 mm) diameter castors.
- 4" (102 mm) diameter castors.
- Ratchet locks.
- Additional lighted shelf (maximum of 3 shelves per cabinet).
- Non-lighted shelves.

PLAN VIEW

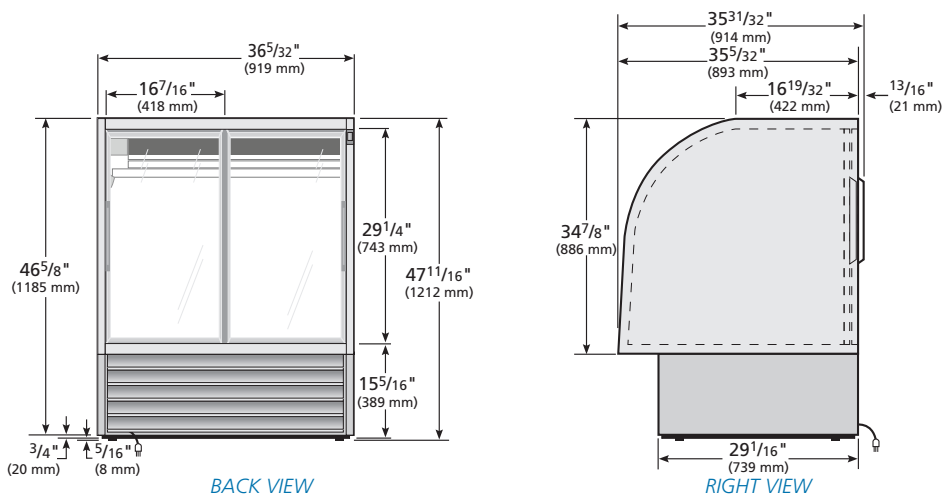

3 YEAR PARTS + LABOR
7 YEAR COMPRESSOR
WARRANTY
(U.S.A. and Canada only)

METRIC DIMENSIONS ROUNDED UP TO THE NEAREST WHOLE MILLIMETER

SPECIFICATIONS SUBJECT TO CHANGE WITHOUT NOTICE



Model	Elevation	Right	Plan	3D	Back
TCGG-36-S-HC-LD					

Models TDM-DC-36-GE/GE-B-W TDM-DC-36-GE/GE-W-W TDM-DC-36-GE/GE-S-W TDM-DC-36-GE/GE-S-S

True Display Merchandiser

Curved Glass, Glass End Dry Case



TDM-DC-36-GE/GE-B-W



TDM-DC-36-GE/GE-W-W



TDM-DC-36-GE/GE-S-S



TDM-DC-36-GE/GE-B-B (optional black interior)

FEATURES

- ▶ True's "dry" display case combines efficient, high volume merchandising with an elegant curved glass front for sophisticated presentation of high end desserts and pastries.
- ▶ Cabinet is NSF/ANSI Standard 2 compliant to hold open food product.
- ▶ Two (2) rear sliding glass doors for back access.
- ▶ Exterior - powder coated FDA black rounded front and back, black aluminum aesthetic side and front panels. Color options available (upcharge may apply) - white or stainless. Curved glass front and side glass panels.
- ▶ Interior - powder coated FDA white over CRS material. Color options available (upcharge may apply) - black or stainless.
- ▶ Three (3) tiered levels of adjustable wire cantilever shelves that match cabinet interior color. Chrome plated wire shelves standard on stainless units.
- ▶ Front glass swings up for easy cleaning access.
- ▶ LED interior lighting provides more even lighting throughout the cabinet. Safety shielded.

STANDARD OPTIONS

Exterior Color	Black, White, or Stainless Steel
Interior Color	Black, White, or Stainless Steel
Glass End (GE)	Clear Glass Interior/Clear Glass Exterior with Black Trim
Shelving	White, Black, Chrome, or Mezzanine

ROUGH-IN DATA

Specifications subject to change without notice. Chart dimensions rounded up to the nearest 1/8" (millimeters rounded up to next whole number).

Model	Doors	Shelves	Cabinet Dimensions (inches) (mm)			Voltage	Amps	NEMA Config.	Cord Length (total ft.) (total m)	Crated Weight White/Black Model (lbs.) (kg)	Crated Weight Stainless Model (lbs.) (kg)
			W	D	H						
TDM-DC-36-GE/GE-Δ-Δ	2	3	36 1/4 921	39 991	49 3/8 1248	115/60/1 230-240/50/1	7.0 0.1	5-15P ▲	8 2.44	485 220	TBD TBD

Δ Represents Exterior/Interior (B-black, W-White, S-Stainless)

▲ Plug type varies by country.

Models:	
TDM-DC-36-GE/GE-B-W	TDM-DC-36-GE/GE-W-W
TDM-DC-36-GE/GE-S-W	TDM-DC-36-GE/GE-S-S

True Display Merchandiser: Curved Glass, Glass End Dry Case



STANDARD FEATURES

- DESIGN**
- True's "dry" display case combines efficient, high volume merchandising with an elegant curved glass front for sophisticated presentation of high end desserts and pastries.
 - Designed to provide an attractive companion to our TDM-R "refrigerated" display merchandiser. Please note: If units are banked together, because of side panel, a 1/2" gap will remain between units.
- CABINET CONSTRUCTION**
- Exterior - powder coated FDA black rounded front and back, black aluminum aesthetic side and front panels. Color options available (upcharge may apply) - white or stainless.
 - Curved glass front and side glass panels.
 - Interior - powder coated FDA white over CRS material. Color options available (upcharge may apply) - black or stainless.
 - Insulation - entire cabinet structure is foamed-in-place using a high density, polyurethane insulation that has zero ozone depletion potential (ODP) and 0.02 global warming potential (GWP).
 - Welded, heavy duty steel frame rail, black powder coated for corrosion protection.
 - Frame rail fitted with leg levelers.

- CURVED FRONT DISPLAY GLASS**
- Curved glass front and side panels are single pane tempered glass. Front glass opens from closed to fully open to provide extra large viewing area to maximize product presentation while allowing full frontal access.
- REAR DOORS**
- Two (2) rear sliding glass doors for back access.
 - Each door fitted with 12" (305 mm) long aluminum handle.
 - Sliding doors ride on stainless steel V-channel with stainless steel bearings. Doors fit within plastic channel frame.
- SHELVING**
- Three (3) adjustable heavy duty PVC coated wire shelves standard.
 - Each shelf supports a maximum weight of 150 lbs. (69 kg).
- PAN CAPACITY**
- Cabinet holds two (2) 18"L x 26"D (458 mm x 661 mm) display pans, two (2) 9"L x 26"D (229 mm x 661 mm) display pans and four (4) 12"L x 18"D (305 mm x 458 mm) display pans. Pans supplied by others.
- LIGHTING**
- LED interior lighting, two (2) clips underneath shelf to keep wires in place. Safety shielded.

- MODEL FEATURES**
- Front glass swings Up for easy cleaning access.
 - NSF/ANSI Standard 2 compliant for open food product.
- ELECTRICAL**
- Unit completely pre-wired at factory and ready for final connection to a 115/60/1 phase, 15 amp dedicated outlet. Cord and plug set included.



- OPTIONAL FEATURES/ACCESSORIES**
Upcharge and lead times may apply.
- 230 - 240V / 50 Hz.
 - White exterior
 - Stainless steel exterior
 - Custom exterior colors (contact factory for details)
 - Black interior
 - Stainless steel interior
 - Black wire shelves
 - Chrome plated wire shelves
 - Stainless mezzanine shelves

TDM MODEL NUMBER NOMENCLATURE SYSTEM

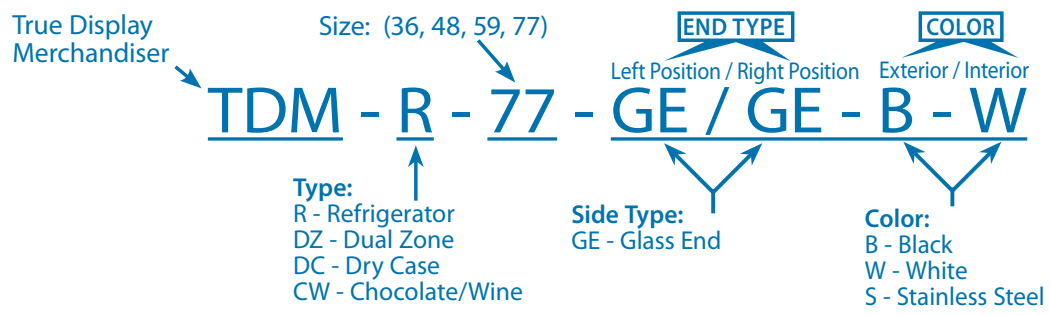

PLAN VIEW

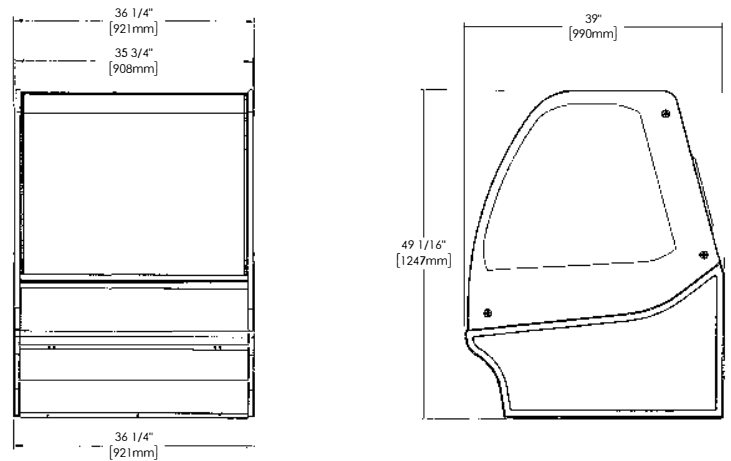

METRIC DIMENSIONS ROUNDED UP TO THE NEAREST WHOLE MILLIMETER
SPECIFICATIONS SUBJECT TO CHANGE WITHOUT NOTICE

	Elevation	Right	Plan	3D	Back

Models TDM-R-36-GE/GE-B-W TDM-R-36-GE/GE-W-W TDM-R-36-GE/GE-S-W TDM-R-36-GE/GE-S-S

True Display Merchandiser

Curved Glass, Glass End Refrigerator



TDM-R-36-GE/GE-B-W



TDM-R-36-GE/GE-W-W



TDM-R-36-GE/GE-S-S



TDM-R-36-GE/GE-B-B (optional black interior)

FEATURES

- ▶ True's refrigerated display merchandisers combine efficient, high volume merchandising and exceptional refrigeration with an elegant curved glass front for sophisticated presentation of high end desserts and pastries.
- ▶ Factory engineered, self-contained, capillary tube system using environmentally friendly R290 hydrocarbon refrigerant that has zero (0) ozone depletion potential (ODP), & 0.02 global warming potential (GWP).
- ▶ High capacity, factory balanced refrigeration system. Standard temperature range maintains cabinet temperatures of 33°F to 41°F (.5°C to 5°C), ideally suited for refrigerated bakery and cold deli products.
- ▶ Cabinet is NSF/ANSI Standard 7 compliant to hold open food product.
- ▶ Two (2) rear sliding glass doors for back access.
- ▶ Exterior - powder coated FDA black rounded front and back, black aluminum aesthetic side and front panels. Color options available (upcharge may apply) - white or stainless. Curved glass front and side glass panels.
- ▶ Interior - powder coated FDA white over CRS material. Color options available (upcharge may apply) - black or stainless.
- ▶ Three (3) tiered levels of adjustable wire cantilever shelves that match cabinet interior color. Chrome plated wire shelves standard on stainless units.
- ▶ Front glass swings Up for easy cleaning access.
- ▶ LED interior lighting provides more even lighting throughout the cabinet. Safety shielded.

STANDARD OPTIONS

Exterior Color	Black, White, or Stainless Steel
Interior Color	Black, White, or Stainless Steel
Glass End (GE)	Clear Glass Interior/Clear Glass Exterior with Black Trim
Shelving	White, Black, Chrome, or Mezzanine

ROUGH-IN DATA

Specifications subject to change without notice. Chart dimensions rounded up to the nearest 1/8" (millimeters rounded up to next whole number).

Model	Doors	Shelves	Cabinet Dimensions (inches) (mm)				HP	Voltage	Amps	NEMA Config.	Cord Length (total ft.) (total m)	Crated Weight White/Black Model (lbs.) (kg)	Crated Weight Stainless Model (lbs.) (kg)
			W	D	H								
TDM-R-36-GE/GE-Δ/Δ	2	3	36 1/4 921	39 991	49 7/8 1248	1/4 1/4	115/60/1 230-240/50/1	10.0 1.8	5-15P ▲	8 2.44	540 245	TBD TBD	

Δ Represents Exterior/Interior (B-black, W-White, S-Stainless)

▲ Plug type varies by country.

Models:	
TDM-R-36-GE/GE-B-W	TDM-R-36-GE/GE-W-W
TDM-R-36-GE/GE-S-W	TDM-R-36-GE/GE-S-S

True Display Merchandiser: Curved Glass, Glass End Refrigerator



STANDARD FEATURES

DESIGN

- True's refrigerated display case combines efficient, high volume merchandising and exceptional refrigeration with an elegant curved glass front for sophisticated presentation of high end deli, desserts and pastries.
- Designed to provide an attractive companion to our TDM-DC "dry case" display merchandiser. Please note: If units are banked together, because of side panel, a 1/2" gap will remain between units.

REFRIGERATION SYSTEM

- Factory engineered, self-contained, capillary tube system using environmentally friendly R290 hydrocarbon refrigerant that has zero (0) ozone depletion potential (ODP), & 0.02 global warming potential (GWP).
- True's self-cleaning RCU technology eliminates the need to clean the condenser coil, reduces energy consumption and helps maintain the coldest temperatures and freshest product.
- High capacity, factory balanced refrigeration system that has two (2) temperature range options. Standard temperature range maintains cabinet temperatures of 33°F to 41°F (5°C to 5°C), ideally suited for refrigerated bakery and cold deli products. Optional temperature range maintains cabinet temperatures of 42°F to 65°F (5.5°C to 18.3°C), ideally suited for chocolate & wine options.
- Pull Out Condensing unit slides out for easy cleaning and maintenance.

CABINET CONSTRUCTION

- Exterior - powder coated FDA black rounded front and back, black aluminum aesthetic side and front panels. Color options available (upcharge may apply) - white or stainless.
- Curved glass front and side glass panels.

- Interior - powder coated FDA white over CRS material. Color options available (upcharge may apply) - black or stainless.
- Insulation - entire cabinet structure is foamed-in-place using a high density, polyurethane insulation that has zero ozone depletion potential (ODP) and zero global warming potential (GWP).
- Welded, heavy duty steel frame rail, black powder coated for corrosion protection.
- Frame rail fitted with leg levelers.

CURVED FRONT DISPLAY GLASS

- Curved glass front and side panels are single pane tempered glass. Front glass opens from closed to fully open to provide extra large viewing area to maximize product presentation while allowing full frontal access.

REAR DOORS

- Two (2) rear sliding glass doors for back access.
- Each door fitted with 12" (305 mm) long aluminum handle.
- Sliding doors ride on stainless steel V-channel with stainless steel bearings. Doors fit within plastic channel frame.

SHELVING

- Three (3) adjustable heavy duty PVC coated wire shelves standard.
- Each shelf supports a maximum weight of 150 lbs. (69 kg).

PAN CAPACITY

- Cabinet holds two (2) 18"L x 26"D (458 mm x 661 mm) display pans, two (2) 9"L x 26"D (229 mm x 661 mm) display pans and four (4) 12"L x 18"D (305 mm x 458 mm) display pans. Pans supplied by others.

LIGHTING

- LED interior lighting, two (2) clips underneath shelf to keep wires in place. Safety shielded.

MODEL FEATURES

- Evaporator is epoxy coated to eliminate the potential of corrosion.
- Front glass swings Up for easy cleaning access.
- Pull out condensing unit slides out for easy cleaning and maintenance.
- Electronic temperature control.
- NSF/ANSI Standard 7 compliant for open food product. Tested and certified for performance at NSF Type II: 80°F (27°C) and 55% relative humidity.

ELECTRICAL

- Unit completely pre-wired at factory and ready for final connection to a 115/60/1 phase, 15 amp dedicated outlet. Cord and plug set included.



OPTIONAL FEATURES/ACCESSORIES
Upcharge and lead times may apply.

- 230 - 240V / 50 Hz.
- White exterior
- Stainless steel exterior
- Custom exterior colors (contact factory for details)
- Black interior
- Stainless steel interior
- Black wire shelves
- Chrome plated wire shelves
- Stainless mezzanine shelves

TDM MODEL NUMBER NOMENCLATURE SYSTEM

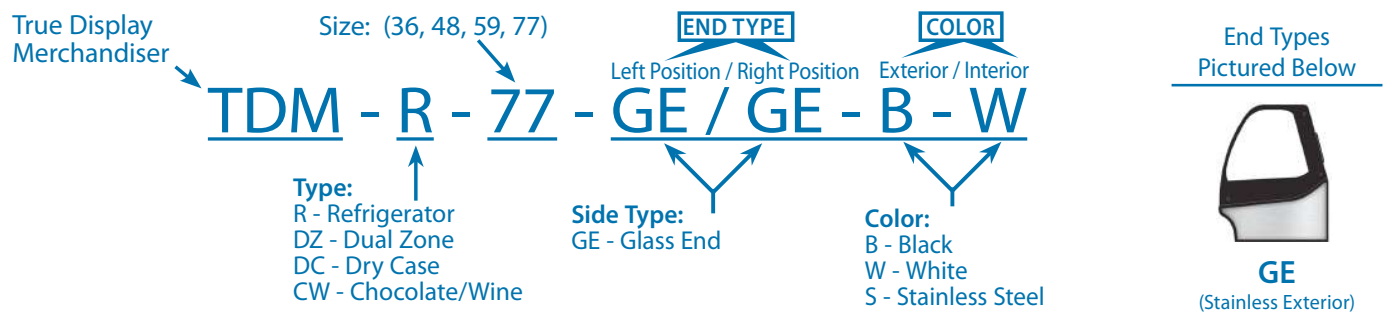

PLAN VIEW

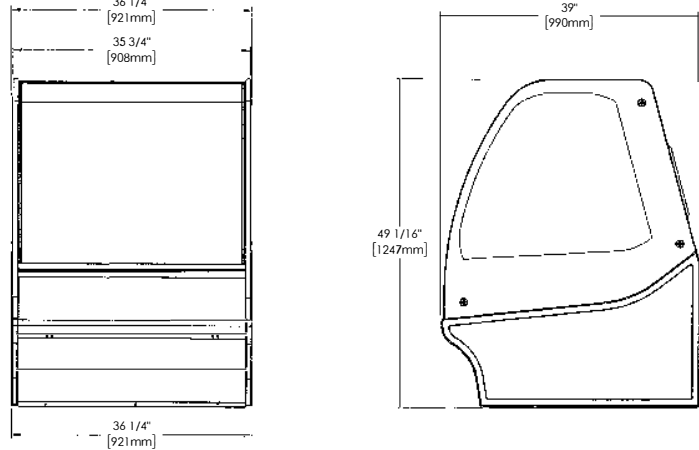

METRIC DIMENSIONS ROUNDED UP TO THE NEAREST WHOLE MILLIMETER
SPECIFICATIONS SUBJECT TO CHANGE WITHOUT NOTICE

	Elevation	Right	Plan	3D	Back

Models TGM-DC-36-SC/SC-B-W TGM-DC-36-SC/SC-W-W TGM-DC-36-SC/SC-S-W TGM-DC-36-SC/SC-S-S

True Glass Merchandiser

Curved Glass, Solid Colored End Dry Case



TGM-DC-36-SC/SC-B-W



TGM-DC-36-SC/SC-W-W



TGM-DC-36-SC/SC-S-W



TGM-DC-36-SC/SC-S-S

FEATURES

- ▶ True's "dry" glass merchandisers combines efficient, high volume merchandising with an elegant curved glass front for sophisticated presentation of high end desserts and pastries.
- ▶ Cabinet is NSF/ANSI Standard 2 compliant to hold open food product.
- ▶ Two (2) rear sliding glass doors for back access.
- ▶ Exterior - powder coated FDA black rounded front and back, solid wood sides with aluminum cover and front panels. Color options available (upcharge may apply) - white or stainless.
- ▶ Interior - powder coated FDA white over CRS material. Color options available (upcharge may apply) - black or stainless.
- ▶ Three (3) tiered levels of adjustable wire cantilever shelves that match cabinet interior color. Chrome plated wire shelves standard on stainless units.
- ▶ Curved glass front is single pane tempered glass with extra large viewing area to maximize product presentation.
- ▶ LED interior lighting provides more even lighting throughout the cabinet. Safety shielded.

STANDARD OPTIONS

Exterior Color	Black, White, or Stainless Steel
Interior Color	Black, White, or Stainless Steel
Shelving	White, Black, Chrome, or Mezzanine

ROUGH-IN DATA

Specifications subject to change without notice.
Chart dimensions rounded up to the nearest 1/8" (millimeters rounded up to next whole number).

Model	Doors	Shelves	Cabinet Dimensions (inches) (mm)			HP	Voltage	Amps	NEMA Config.	Cord Length (total ft.) (total m)	Crated Weight White/Black Model (lbs.) (kg)	Crated Weight Stainless Model (lbs.) (kg)
			W	D	H							
TGM-R-36-SC/SC-B-W	2	6	36 1/4 921	39 990	49 3/8 1247	1/4 1/4 1/4	115/60/1 230-240/50/1 220/60/1	10.0 1.8 2.4	5-15P ▲ ▲	8 2.44	TBD TBD	TBD TBD

▲ Represents Exterior/Interior (B-black, W-White, S-Stainless)

Models:	
TGM-DC-36-SC/SC-B-W	TGM-DC-36-SC/SC-W-W
TGM-DC-36-SC/SC-S-W	TGM-DC-36-SC/SC-S-S

True Glass Merchandiser:

Curved Glass, Solid Colored End Dry Case



STANDARD FEATURES

DESIGN

- True's dry display case glass merchandiser combines efficient, high volume merchandising and exceptional refrigeration with an elegant curved glass front for sophisticated presentation of high end deli, desserts and pastries.
- Designed to provide an attractive companion to our TGM-R "refrigerated" glass merchandiser. Please note: If units are banked together, because of side panel, a 1/2" (13mm) gap will remain between units.

CABINET CONSTRUCTION

- Exterior - powder coated FDA black rounded front and back, solid wood sides with aluminum cover and front panels. Color options available (upcharge may apply) - white or stainless.
- Curved glass front and side glass panels.
- Interior - powder coated FDA white over CRS material. Color options available (upcharge may apply) - black or stainless.
- Insulation - entire cabinet structure is foamed-in-place using a high density, polyurethane insulation that has zero ozone depletion potential (ODP) and zero global warming potential (GWP).
- Welded, heavy duty steel frame rail, black powder coated for corrosion protection.
- Frame rail fitted with leg levelers.

CURVED FRONT DISPLAY GLASS

- Curved glass front is single pane tempered glass with extra large viewing area to maximize product presentation.

REAR DOORS

- Two (2) rear sliding glass doors for back access.

- Each door fitted with 12" (305 mm) long aluminum handle.
- Sliding doors ride on stainless steel V-channel with stainless steel bearings. Doors fit within plastic channel frame.

SHELVING

- Six (6) adjustable heavy duty PVC coated wire shelves standard.
- Each shelf supports a maximum weight of 150 lbs. (69 kg).

PAN CAPACITY

- Cabinet holds two (2) 18"L x 26"D (458 mm x 661 mm) display pans, two (2) 9"L x 26"D (229 mm x 661 mm) display pans and four (4) 12"L x 18"D (305 mm x 458 mm) display pans. Pans supplied by others.

LIGHTING

- LED interior lighting, two (2) clips underneath shelf to keep wires in place. Safety shielded.

MODEL FEATURES

- NSF/ANSI Standard 2 compliant for open food product.

ELECTRICAL

- Unit completely pre-wired at factory and ready for final connection to a 115/60/1 phase, 15 amp dedicated outlet. Cord and plug set included.



115/60/1
NEMA-5-15R

STANDARD OPTIONS

Upcharge and lead times may apply.

- Black exterior
- White exterior
- Stainless steel exterior
- White interior
- Black interior
- Stainless steel interior
- Solid Colored Exterior Sides with color matching interior (SC)
- White wire shelves
- Black wire shelves
- Chrome plated wire shelves
- Stainless steel mezzanine shelves

OPTIONAL FEATURES/ACCESSORIES

Upcharge and lead times may apply.

- 230 - 240V / 50 Hz.
- 208 - 230V / 60 Hz.
- Custom exterior colors (contact factory for details)
- Glass shelves
- Frosted glass shelves
- Ratchet lock
- Electrical Receptacle
- Exterior top scale shelf
- Exterior small top service shelf
- Exterior medium top service shelf
- Exterior large top service shelf
- External front shelf kit (only available in black)
- External rear service shelf shelf kit (only available in black)
- 4" (102mm) Castors
- 2 1/2" (64mm) castors
- 6" (153mm) legs

TGM MODEL NUMBER NOMENCLATURE SYSTEM

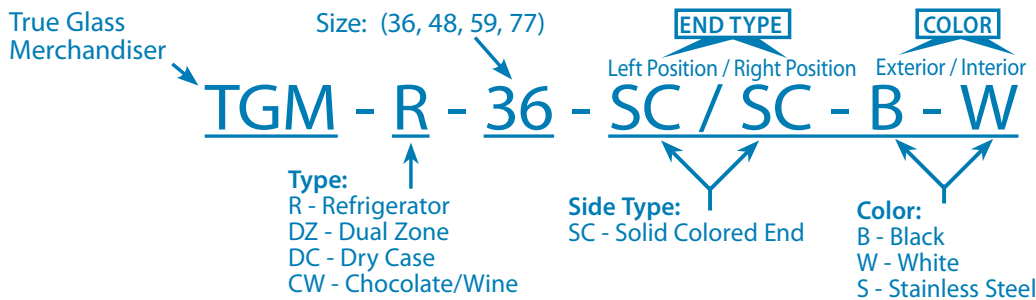

PLAN VIEW

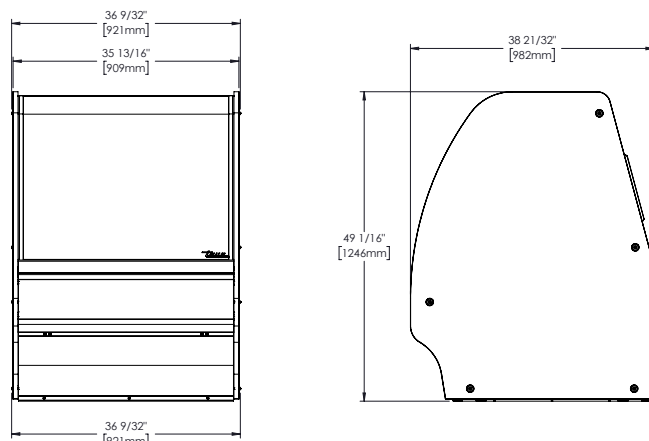

METRIC DIMENSIONS ROUNDED UP TO THE NEAREST WHOLE MILLIMETER
SPECIFICATIONS SUBJECT TO CHANGE WITHOUT NOTICE

	Elevation	Right	Plan	3D	Back

Models TGM-R-36-SC/SC-B-W TGM-R-36-SC/SC-W-W TGM-R-36-SC/SC-S-W TGM-R-36-SC/SC-S-S

True Glass Merchandiser

Curved Glass, Solid Colored End Refrigerator



TGM-R-36-SC/SC-B-W



TGM-R-36-SC/SC-W-W



TGM-R-36-SC/SC-S-W



TGM-R-36-SC/SC-S-S

FEATURES

- ▶ True's refrigerated glass merchandisers combine efficient, high volume merchandising and exceptional refrigeration with an elegant curved glass front for sophisticated presentation of high end desserts and pastries.
- ▶ Factory engineered, self-contained, capillary tube system using environmentally friendly R290 hydrocarbon refrigerant that has zero (0) ozone depletion potential (ODP), & 0.02 global warming potential (GWP).
- ▶ High capacity, factory balanced refrigeration system. Standard temperature range maintains cabinet temperatures of 33°F to 41°F (.5°C to 5°C), ideally suited for refrigerated bakery and cold deli products.
- ▶ Cabinet is NSF/ANSI Standard 7 compliant to hold open food product.
- ▶ Two (2) rear sliding glass doors for back access.
- ▶ Exterior - powder coated FDA black rounded front and back, solid wood sides with aluminum cover and front panels. Color options available (upcharge may apply) - white or stainless.
- ▶ Interior - powder coated FDA white over CRS material. Color options available (upcharge may apply) - black or stainless.
- ▶ Three (3) tiered levels of adjustable wire cantilever shelves that match cabinet interior color. Chrome plated wire shelves standard on stainless units.
- ▶ Curved glass front is single pane tempered glass with extra large viewing area to maximize product presentation.
- ▶ LED interior lighting provides more even lighting throughout the cabinet. Safety shielded.

STANDARD OPTIONS

Exterior Color	Black, White, or Stainless Steel
Interior Color	Black, White, or Stainless Steel
Shelving	White, Black, Chrome, or Mezzanine

ROUGH-IN DATA

Specifications subject to change without notice. Chart dimensions rounded up to the nearest 1/8" (millimeters rounded up to next whole number).

Model	Doors	Shelves	Cabinet Dimensions (inches) (mm)			HP	Voltage	Amps	NEMA Config.	Cord Length (total ft.) (total m)	Crated Weight White/Black Model (lbs.) (kg)	Crated Weight Stainless Model (lbs.) (kg)
			W	D	H							
TGM-R-36-SC/SC-Δ-Δ	2	6	36 1/4 921	39 990	49 3/8 1247	1/4 1/4 1/4	115/60/1 220-240V/50Hz 220V/60Hz	10.0 1.8 2.4	5-15P ▲ ▲	8 2.44	TBD TBD	TBD TBD

Δ Represents Exterior/Interior (B-black, W-White, S-Stainless)

▲ Plug type varies by country.

Models:		True Glass Merchandiser:	
TGM-R-36-SC/SC-B-W	TGM-R-36-SC/SC-W-W	<i>Curved Glass, Solid Colored End Refrigerator</i>	
TGM-R-36-SC/SC-S-W	TGM-R-36-SC/SC-S-S		

STANDARD FEATURES

DESIGN

- True's refrigerated display case glass merchandiser combines efficient, high volume merchandising and exceptional refrigeration with an elegant curved glass front for sophisticated presentation of high end deli, desserts and pastries.
- Designed to provide an attractive companion to our TGM-DC "dry case" display merchandiser. Please note: If units are banked together, because of side panel, a 1/2" (13mm) gap will remain between units.

REFRIGERATION SYSTEM

- Factory engineered, self-contained, capillary tube system using environmentally friendly R290 hydrocarbon refrigerant that has zero (0) ozone depletion potential (ODP), & 0.02 global warming potential (GWP).
- True's self-cleaning RCU technology eliminates the need to clean the condenser coil, reduces energy consumption and helps maintain the coldest temperatures and freshest product.
- High capacity, factory balanced refrigeration system that has two (2) temperature range options. Standard temperature range maintains cabinet temperatures of 33°F to 41°F (.5°C to 5°C), ideally suited for refrigerated bakery and cold deli products. Optional temperature range maintains cabinet temperatures of 42°F to 65°F (5.5°C to 18.3°C), ideally suited for chocolate & wine options.
- Pull Out Condensing unit slides out for easy cleaning and maintenance.

CABINET CONSTRUCTION

- Exterior - powder coated FDA black rounded front and back, solid wood sides with aluminum cover and front panels. Color options available (upcharge may apply) - white or stainless.
- Curved glass front and side glass panels.
- Interior - powder coated FDA white over CRS material. Color options available (upcharge may apply) - black or stainless.
- Insulation - entire cabinet structure is foamed-in-place using a high density, polyurethane insulation that has zero ozone depletion potential (ODP) and zero global warming potential (GWP).
- Welded, heavy duty steel frame rail, black powder coated for corrosion protection.
- Frame rail fitted with leg levelers.

CURVED FRONT DISPLAY GLASS

- Curved glass front is single pane tempered glass with extra large viewing area to maximize product presentation.

REAR DOORS

- Two (2) rear sliding glass doors for back access.
- Each door fitted with 12" (305 mm) long aluminum handle.
- Sliding doors ride on stainless steel V-channel with stainless steel bearings. Doors fit within plastic channel frame.

SHELVING

- Six (6) adjustable heavy duty PVC coated wire shelves standard.
- Each shelf supports a maximum weight of 150 lbs. (69 kg).

PAN CAPACITY

- Cabinet holds two (2) 18"L x 26"D (458 mm x 661 mm) display pans, two (2) 9"L x 26"D (229 mm x 661 mm) display pans and four (4) 12"L x 18"D (305 mm x 458 mm) display pans. Pans supplied by others.

LIGHTING

- LED interior lighting, two (2) clips underneath shelf to keep wires in place. Safety shielded.

MODEL FEATURES

- Evaporator is epoxy coated to eliminate the potential of corrosion.
- Pull out condensing unit slides out for easy cleaning and maintenance.
- Electronic temperature control.
- NSF/ANSI Standard 7 compliant for open food product. Tested and certified for performance at NSF Type II: 80°F (27°C) and 55% relative humidity.

ELECTRICAL

- Unit completely pre-wired at factory and ready for final connection to a 115/60/1 phase, 15 amp dedicated outlet. Cord and plug set included.

STANDARD OPTIONS

Upcharge and lead times may apply.

- Black exterior
- White exterior
- Stainless steel exterior
- White interior
- Black interior
- Stainless steel interior
- Solid Colored Exterior Sides with color matching interior (SC)
- White wire shelves
- Black wire shelves
- Chrome plated wire shelves
- Stainless steel mezzanine shelves

OPTIONAL FEATURES/ACCESSORIES

Upcharge and lead times may apply.

- 220-240V/50Hz
- 220V/60Hz
- Custom exterior colors (contact factory for details)
- Chocolate/Wine model available
- Glass shelves
- Frosted glass shelves
- Ratchet lock
- Electrical Receptacle
- Exterior top scale shelf
- Exterior small top service shelf
- Exterior medium top service shelf
- External front shelf kit (only available in black)
- External rear service shelf shelf kit (only available in black)
- 4" (102mm) Castors
- 2 1/2" (64mm) castors
- 6" (153mm) legs
- 230 - 240V / 50 Hz.
- 220V / 60 Hz.



TGM MODEL NUMBER NOMENCLATURE SYSTEM

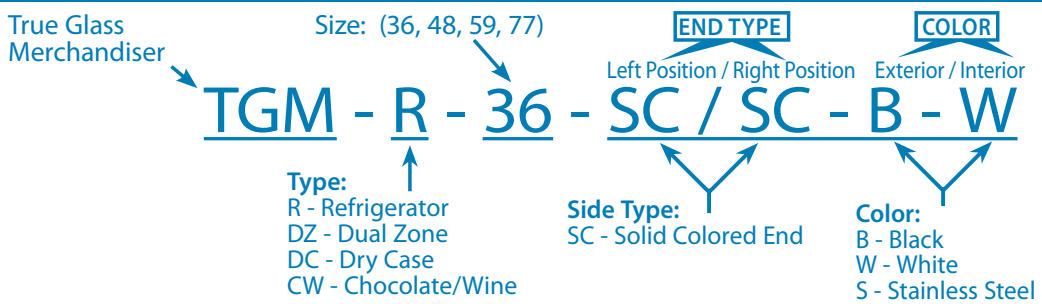

PLAN VIEW

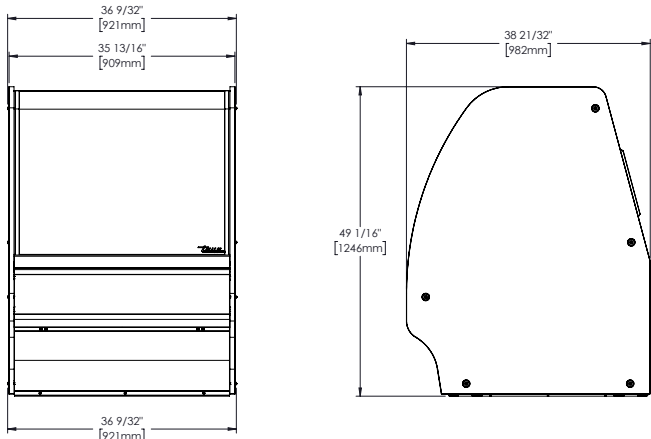

METRIC DIMENSIONS ROUNDED UP TO THE NEAREST WHOLE MILLIMETER
SPECIFICATIONS SUBJECT TO CHANGE WITHOUT NOTICE

	Elevation	Right	Plan	3D	Back

Model:
TCGG-48-HC-LD

Display Case:

Curved Glass Refrigerated Deli Case with Hydrocarbon Refrigerant and LED Lighting



TCGG-48-HC-LD

- ▶ True's curved glass deli case combines efficient, high volume merchandising and exceptional refrigeration with an elegant curved glass front for sophisticated presentation of deli products.
- ▶ High humidity gravity coil refrigeration system maintains 38°F to 40°F (3.3°C to 4.4°C) for the freshest display of meats, cheeses and deli products.
- ▶ Factory engineered, self-contained, capillary tube system using environmentally friendly R290 hydrocarbon refrigerant that has zero (0) ozone depletion potential (ODP), & three (3) global warming potential (GWP).
- ▶ Cabinet is NSF/ANSI Standard 7 certified to hold open food product.
- ▶ Insulated double pane curved front glass provides maximum insulation value for greater efficiency and energy savings. Both panes are tempered for safety.
- ▶ Two (2) adjustable, lighted, cantilevered PVC coated shelves.
- ▶ LED lights are low UV emitting to enhance product appearance and increase shelf life.
- ▶ Exterior - durable and permanent no peel or chip white powder coated cold rolled steel with stainless steel top and trim.
- ▶ White aluminum interior sides and top. Stainless steel floor with coved corners.

ROUGH-IN DATA

Chart dimensions rounded up to the nearest 1/8" (millimeters rounded up to next whole number). Specifications subject to change without notice.

Model	Doors	Shelves	Cabinet Dimensions (inches) (mm)			HP	Voltage	Amps	NEMA Config.	Cord Length (total ft.) (total m)	Crated Weight (lbs.) (kg)
			W	D†	H						
TCGG-48-HC-LD	2	2	48 1/4 1226	35 1/4 896	47 3/4 1213	1/3 N/A	115/60/1	3.3 N/A	5-15P	9 2.74	550 250

† Depth does not include 7/8" (23 mm) for door handles.

Model:
TCGG-48-HC-LD

Display Case:
*Curved Glass Refrigerated Deli Case with
Hydrocarbon Refrigerant and LED Lighting*



STANDARD FEATURES

DESIGN

- True's curved glass deli display case combines efficient, high volume merchandising and exceptional refrigeration with an elegant curved glass front for sophisticated presentation of deli products.
- Gravity coil refrigeration system guarantees the freshest display of meats, cheeses and deli products.

REFRIGERATION SYSTEM

- Factory engineered, self-contained, capillary tube system using environmentally friendly R290 hydrocarbon refrigerant that has zero (0) ozone depletion potential (ODP), & three (3) global warming potential (GWP).
- Extra large evaporator coil balanced with higher horsepower compressor and large condenser maintains 38°F to 40°F (3.3°C to 4.4°C).
- High humidity gravity coil refrigeration system. Ideally suited for deli meats, cheeses and salads.
- Condensing unit located behind panel in back of unit. Entire system slides out for easy cleaning and maintenance.
- Automatic defrost system; time-initiated, time-terminated.

CABINET CONSTRUCTION

- Exterior - durable and permanent no peel or chip white powder coated cold rolled steel with stainless steel top and trim.
- Interior - White aluminum sides and top with stainless steel floor.

- Insulation - entire cabinet structure is foamed-in-place using a high density, polyurethane insulation that has zero ozone depletion potential (ODP) and zero global warming potential (GWP).
- Welded, heavy duty steel frame rail, black powder coated for corrosion protection.
- Frame rail fitted with leg levelers.

CURVED FRONT DISPLAY GLASS

- Insulated double pane glass provides maximum insulation value for greater efficiency and energy savings. Both panes are tempered for safety.

REAR DOORS

- "Low-E", double pane thermal glass inserts with mitered plastic channel frames.
- Each door fitted with 12" (305 mm) long molded plastic handle.
- Self-closing doors, efficient counter balanced weight system for smooth, even, positive closure. Sliding doors ride on stainless steel V-channel with stainless steel bearings. Doors fit within plastic channel frame.

SHELVING

- Two (2) adjustable, lighted, white heavy duty PVC coated wire shelves 42⁷/₈" L x 22⁵/₂" D (1090 mm x 563 mm). Shelving system is cantilevered with adjustable angle to maximize presentation.

LIGHTING

- Cabinet equipped with three LED (3) light sources for maximum product display; two (2) shelf mounted and one (1) cabinet mounted.

MODEL FEATURES

- Evaporator is epoxy coated to eliminate the potential of corrosion.
- Four (4) amp exterior scale receptacle.
- NSF/ANSI Standard 7 compliant for open food product.

ELECTRICAL

- Unit completely pre-wired at factory and ready for final connection to a 115/60/1 phase, 15 amp dedicated outlet. Cord and plug set included.



115/60/1
NEMA-5-15R

RECOMMENDED OPERATING CONDITIONS

- TCGG refrigerated models are designed to operate in an environment where temperature and humidity do not exceed 75°F (24°C) and 55% relative humidity.

OPTIONAL FEATURES/ACCESSORIES

Upcharge and lead times may apply.

- 6" (153 mm) standard legs.
- 6" (153 mm) seismic/flanged legs.
- 2 1/2" (64 mm) diameter castors.
- 4" (102 mm) diameter castors.
- Ratchet locks.
- Additional lighted shelves.
- Non-lighted shelves.

PLAN VIEW

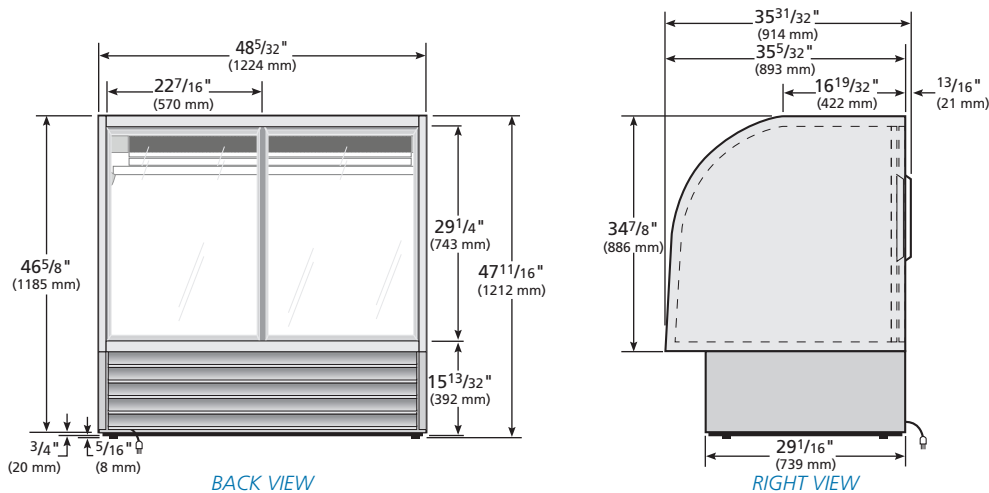

3 YEAR PARTS + LABOR
7 YEAR COMPRESSOR
WARRANTY
 (U.S.A. and Canada only)

METRIC DIMENSIONS ROUNDED UP TO THE NEAREST WHOLE MILLIMETER

SPECIFICATIONS SUBJECT TO CHANGE WITHOUT NOTICE



Model	Elevation	Right	Plan	3D	Back
TCGG-48-HC-LD					

Model:
TCGG-48-S-HC-LD

Display Case:

Stainless Steel Curved Glass Refrigerated Deli Case with Hydrocarbon Refrigerant and LED Lighting



TCGG-48-S-HC-LD

- ▶ True's curved glass deli case combines efficient, high volume merchandising and exceptional refrigeration with an elegant curved glass front for sophisticated presentation of deli products.
- ▶ High humidity gravity coil refrigeration system maintains 38°F to 40°F (3.3°C to 4.4°C) for the freshest display of meats, cheeses and deli products.
- ▶ Factory engineered, self-contained, capillary tube system using environmentally friendly R290 hydrocarbon refrigerant that has zero (0) ozone depletion potential (ODP), & three (3) global warming potential (GWP).
- ▶ Cabinet is NSF/ANSI Standard 7 certified to hold open food product.
- ▶ Insulated double pane curved front glass provides maximum insulation value for greater efficiency and energy savings. Both panes are tempered for safety.
- ▶ Two (2) adjustable, lighted, cantilevered PVC coated shelves.
- ▶ LED lights are low UV emitting to enhance product appearance and increase shelf life.
- ▶ All stainless steel interior and exterior.

ROUGH-IN DATA

Chart dimensions rounded up to the nearest 1/8" (millimeters rounded up to next whole number). Specifications subject to change without notice.

Model	Doors	Shelves	Cabinet Dimensions (inches) (mm)			HP	Voltage	Amps	NEMA Config.	Cord Length (total ft.) (total m)	Crated Weight (lbs.) (kg)
			W	D†	H						
TCGG-48-S-HC-LD	2	2	48 1/4 1226	35 1/4 896	47 3/4 1213	1/3 N/A	115/60/1	3.3 N/A	5-15P	9 2.74	465 211

† Depth does not include 7/8" (23 mm) for door handles.

Model:
TCGG-48-S-HC-LD

Display Case:

Stainless Steel Curved Glass Refrigerated Deli Case with Hydrocarbon Refrigerant and LED Lighting



STANDARD FEATURES

DESIGN

- True's curved glass deli display case combines efficient, high volume merchandising and exceptional refrigeration with an elegant curved glass front for sophisticated presentation of deli products.
- Gravity coil refrigeration system guarantees the freshest display of meats, cheeses and deli products.

REFRIGERATION SYSTEM

- Factory engineered, self-contained, capillary tube system using environmentally friendly R290 hydrocarbon refrigerant that has zero (0) ozone depletion potential (ODP), & three (3) global warming potential (GWP).
- High capacity, Factory balanced refrigeration system maintains 38°F to 40°F (3.3°C to 4.4°C).
- High humidity gravity coil refrigeration system. Ideally suited for deli meats, cheeses and salads.
- Condensing unit located behind panel in back of unit. Entire system slides out for easy cleaning and maintenance.
- Automatic defrost system; time-initiated, time-terminated.

CABINET CONSTRUCTION

- Exterior - all stainless steel front, sides, back and top.
- Interior - all stainless steel sides and stainless steel floor with coved corners.

- Insulation - entire cabinet structure is foamed-in-place using a high density, polyurethane insulation that has zero ozone depletion potential (ODP) and zero global warming potential (GWP).
- Welded, heavy duty steel frame rail, black powder coated for corrosion protection.
- Frame rail fitted with leg levelers.

CURVED FRONT DISPLAY GLASS

- Insulated double pane glass provides maximum insulation value for greater efficiency and energy savings. Both panes are tempered for safety.

REAR DOORS

- "Low-E", double pane thermal glass inserts with mitered plastic channel frames.
- Each door fitted with 12" (305 mm) long molded plastic handle.
- Self-closing doors, efficient counter balanced weight system for smooth, even, positive closure. Sliding doors ride on stainless steel V-channel with stainless steel bearings. Doors fit within plastic channel frame.

SHELVING

- Two (2) adjustable, lighted, white heavy duty PVC coated wire shelves 42 7/8" L x 22 5/32" D (1090 mm x 563 mm). Shelving system is cantilevered with adjustable angle to maximize presentation.

LIGHTING

- Cabinet equipped with three LED (3) light sources for maximum product display; two (2) shelf mounted and one (1) cabinet mounted.

MODEL FEATURES

- Evaporator is epoxy coated to eliminate the potential of corrosion.
- Four (4) amp exterior scale receptacle.
- NSF/ANSI Standard 7 compliant for open food product.

ELECTRICAL

- Unit completely pre-wired at factory and ready for final connection to a 115/60/1 phase, 15 amp dedicated outlet. Cord and plug set included.



115/60/1
NEMA-5-15R

RECOMMENDED OPERATING CONDITIONS

- TCGG refrigerated models are designed to operate in an environment where temperature and humidity do not exceed 75°F (24°C) and 55% relative humidity.

OPTIONAL FEATURES/ACCESSORIES

Upcharge and lead times may apply.

- 6" (153 mm) standard legs.
- 6" (153 mm) seismic/flanged legs.
- 2 1/2" (64 mm) diameter castors.
- 4" (102 mm) diameter castors.
- Ratchet locks.
- Additional lighted shelves.
- Non-lighted shelves.

PLAN VIEW

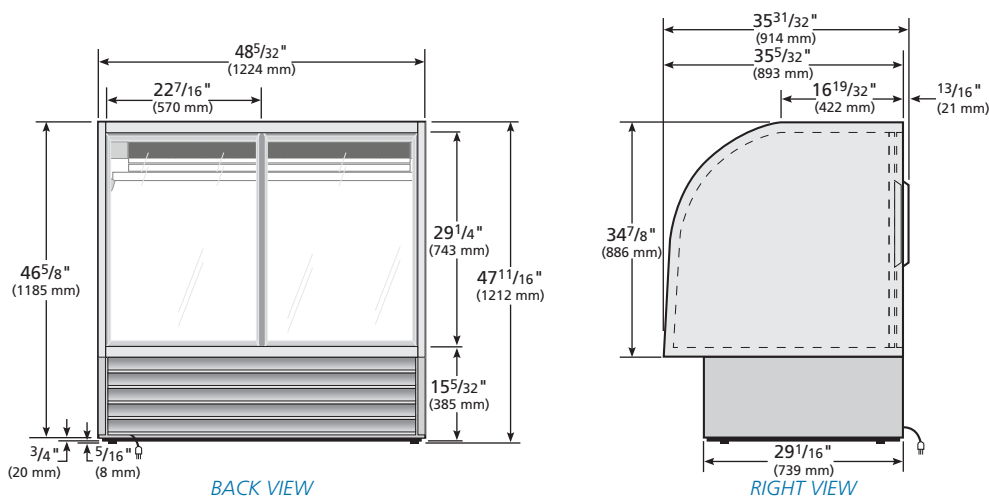

3 YEAR PARTS + LABOR
7 YEAR COMPRESSOR
WARRANTY
(U.S.A. and Canada only)

METRIC DIMENSIONS ROUNDED UP TO THE NEAREST WHOLE MILLIMETER

SPECIFICATIONS SUBJECT TO CHANGE WITHOUT NOTICE



Model	Elevation	Right	Plan	3D	Back
TCGG-48-S-HC-LD					

Models TDM-DC-48-GE/GE-B-W TDM-DC-48-GE/GE-W-W TDM-DC-48-GE/GE-S-W TDM-DC-48-GE/GE-S-S

True Display Merchandiser

Curved Glass, Glass End Dry Case



TDM-DC-48-GE/GE-B-W



TDM-DC-48-GE/GE-W-W



TDM-DC-48-GE/GE-S-S



TDM-DC-48-GE/GE-B-B (optional black interior)

FEATURES

- ▶ True's "dry" display case combines efficient, high volume merchandising with an elegant curved glass front for sophisticated presentation of high end desserts and pastries.
- ▶ Cabinet is NSF/ANSI Standard 2 compliant to hold open food product.
- ▶ Two (2) rear sliding glass doors for back access.
- ▶ Exterior - powder coated FDA black rounded front and back, black aluminum aesthetic side and front panels. Color options available (upcharge may apply) - white or stainless. Curved glass front and side glass panels.
- ▶ Interior - powder coated FDA white over CRS material. Color options available (upcharge may apply) - black or stainless.
- ▶ Three (3) tiered levels of adjustable wire cantilever shelves that match cabinet interior color. Chrome plated wire shelves standard on stainless units.
- ▶ Front glass swings Up for easy cleaning access.
- ▶ LED interior lighting provides more even lighting throughout the cabinet. Safety shielded.

STANDARD OPTIONS

Exterior Color	Black, White, or Stainless Steel
Interior Color	Black, White, or Stainless Steel
Glass End (GE)	Clear Glass Interior/Clear Glass Exterior with Black Trim
Shelving	White, Black, Chrome, or Mezzanine

ROUGH-IN DATA

Specifications subject to change without notice. Chart dimensions rounded up to the nearest 1/8" (millimeters rounded up to next whole number).

Model	Doors	Shelves	Cabinet Dimensions (inches) (mm)			Voltage	Amps	NEMA Config.	Cord Length (total ft.) (total m)	Crated Weight White/Black Model (lbs.) (kg)	Crated Weight Stainless Model (lbs.) (kg)
			W	D	H						
TDM-DC-48-GE/GE-B-W	2	3	48 1/4 1226	39 991	49 1/8 1248	115/60/1 220-240V/50Hz 220V/60Hz	7.0 0.1 0.1	5-15P ▲ ▲	8 2.44	580 263	TBD TBD

Δ Represents Exterior/Interior (B-black, W-White, S-Stainless)

▲ Plug type varies by country.

Models:	
TDM-DC-48-GE/GE-B-W	TDM-DC-48-GE/GE-W-W
TDM-DC-48-GE/GE-S-W	TDM-DC-48-GE/GE-S-S

True Display Merchandiser: Curved Glass, Glass End Dry Case



STANDARD FEATURES

DESIGN

- True's "dry" display case combines efficient, high volume merchandising with an elegant curved glass front for sophisticated presentation of high end desserts and pastries.
- Designed to provide an attractive companion to our TDM-R "refrigerated" display merchandiser. Please note: If units are banked together, because of side panel, a 1/2" gap will remain between units.

CABINET CONSTRUCTION

- Exterior - powder coated FDA black rounded front and back, black aluminum aesthetic side and front panels. Color options available (upcharge may apply) - white or stainless.
- Curved glass front and side glass panels.
- Interior - powder coated FDA white over CRS material. Color options available (upcharge may apply) - black or stainless.
- Insulation - entire cabinet structure is foamed-in-place using a high density, polyurethane insulation that has zero ozone depletion potential (ODP) and 0.02 global warming potential (GWP).
- Welded, heavy duty steel frame rail, black powder coated for corrosion protection.
- Frame rail fitted with leg levelers.

CURVED FRONT DISPLAY GLASS

- Curved glass front and side panels are single pane tempered glass. Front glass opens from closed to fully open to provide extra large viewing area to maximize product presentation while allowing full frontal access.

REAR DOORS

- Two (2) rear sliding glass doors for back access.
- Each door fitted with 12" (305 mm) long aluminum handle.
- Sliding doors ride on stainless steel V-channel with stainless steel bearings. Doors fit within plastic channel frame.

SHELVING

- Three (3) adjustable heavy duty PVC coated wire shelves standard.
- Each shelf supports a maximum weight of 150 lbs. (69 kg).

PAN CAPACITY

- Cabinet holds four (4) 18"L x 26"D (458 mm x 661 mm) display pans, two (2) 9"L x 26"D (229 mm x 661 mm) display pans and six (6) 12"L x 18"D (305 mm x 458 mm) display pans. Pans supplied by others.

LIGHTING

- LED interior lighting, two (2) clips underneath shelf to keep wires in place. Safety shielded.

MODEL FEATURES

- Front glass swings Up for easy cleaning access.
- NSF/ANSI Standard 2 compliant for open food product.

ELECTRICAL

- Unit completely pre-wired at factory and ready for final connection to a 115/60/1 phase, 15 amp dedicated outlet. Cord and plug set included.



- OPTIONAL FEATURES/ACCESSORIES**
Upcharge and lead times may apply.
- 220-240V/50Hz
 - 220V/60Hz
 - White exterior
 - Stainless steel exterior
 - Custom exterior colors (contact factory for details)
 - Black interior
 - Stainless steel interior
 - Black wire shelves
 - Chrome plated wire shelves
 - Stainless mezzanine shelves

TDM MODEL NUMBER NOMENCLATURE SYSTEM

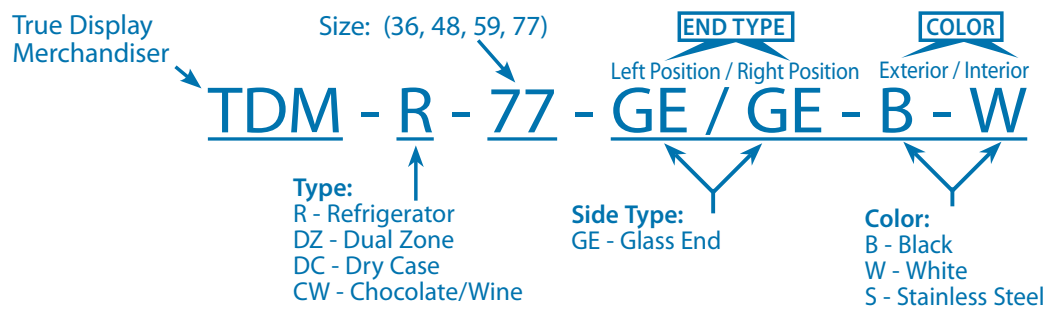

PLAN VIEW

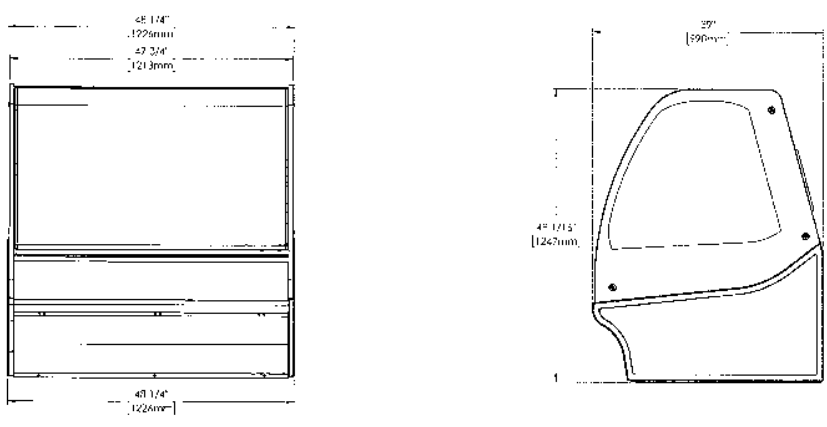

METRIC DIMENSIONS ROUNDED UP TO THE NEAREST WHOLE MILLIMETER
SPECIFICATIONS SUBJECT TO CHANGE WITHOUT NOTICE

	Elevation	Right	Plan	3D	Back

Models TDM-DZ-48-GE/GE-B-W TDM-DZ-48-GE/GE-W-W TDM-DZ-48-GE/GE-S-W TDM-DZ-48-GE/GE-S-S

True Display Merchandiser

Curved Glass, Glass End Dual Zone



TDM-DZ-48-GE/GE-B-W



TDM-DZ-48-GE/GE-W-W



TDM-DZ-48-GE/GE-S-S



TDM-DZ-48-GE/GE-B-B (optional black interior)

FEATURES

- ▶ True's refrigerated display merchandisers combine efficient, high volume merchandising and exceptional refrigeration with an elegant curved glass front for sophisticated presentation of high end desserts and pastries.
- ▶ Factory engineered, self-contained, capillary tube system using environmentally friendly R290 hydrocarbon refrigerant that has zero (0) ozone depletion potential (ODP), & 0.02 global warming potential (GWP).
- ▶ Refrigerated section features high capacity, factory balanced refrigeration system. Standard temperature range maintains cabinet temperatures of 33°F to 41°F (.5°C to 5°C), ideally suited for refrigerated bakery and cold deli products.
- ▶ Cabinet is NSF/ANSI Standard 7 compliant to hold open food product.
- ▶ Two (2) rear sliding glass doors for back access.
- ▶ Exterior - powder coated FDA black rounded front and back, black aluminum aesthetic side and front panels. Color options available (upcharge may apply) - white or stainless. Curved glass front and side glass panels.
- ▶ Interior - powder coated FDA white over CRS material. Color options available (upcharge may apply) - black or stainless.
- ▶ Six (6) tiered levels of adjustable wire cantilever shelves that match cabinet interior color. Chrome plated wire shelves standard on stainless units.
- ▶ Front glass swings Up for easy cleaning access.
- ▶ LED interior lighting provides more even lighting throughout the cabinet. Safety shielded.

STANDARD OPTIONS

Exterior Color	Black, White, or Stainless Steel
Interior Color	Black, White, or Stainless Steel
Glass End (GE)	Clear Glass Interior/Clear Glass Exterior with Black Trim
Shelving	White, Black, Chrome, or Mezzanine

ROUGH-IN DATA

Specifications subject to change without notice. Chart dimensions rounded up to the nearest 1/8" (millimeters rounded up to next whole number).

Model	Doors	Shelves	Cabinet Dimensions (inches) (mm)			HP	Voltage	Amps	NEMA Config.	Cord Length (total ft.) (total m)	Crated Weight White/Black Model (lbs.) (kg)	Crated Weight Stainless Model (lbs.) (kg)
			W	D	H							
TDM-DZ-48-GE/GE-Δ/Δ	2	6	48 1/4 1226	39 991	49 7/8 1248	1/4 1/4	115/60/1 230-240/50/1	10.0 1.7	5-15P ▲	8 2.44	690 313	TBD TBD

Δ Represents Exterior/Interior (B-black, W-White, S-Stainless)

▲ Plug type varies by country.

Models:	
TDM-DZ-48-GE/GE-B-W	TDM-DZ-48-GE/GE-W-W
TDM-DZ-48-GE/GE-S-W	TDM-DZ-48-GE/GE-S-S

True Display Merchandiser: Curved Glass, Glass End Dual Zone



STANDARD FEATURES

DESIGN

- True's combination "refrigerated" and "dry" display case combines efficient, high volume merchandising and exceptional refrigeration with an elegant curved glass front for sophisticated presentation of high end deli, desserts and pastries.
- Please note: If units are banked together, because of side panel, a 1/2" gap will remain between units.

REFRIGERATION SYSTEM

- Factory engineered, self-contained, capillary tube system using environmentally friendly R290 hydrocarbon refrigerant that has zero (0) ozone depletion potential (ODP), & 0.02 global warming potential (GWP).
- True's self-cleaning RCU technology eliminates the need to clean the condenser coil, reduces energy consumption and helps maintain the coldest temperatures and freshest product.
- High capacity, factory balanced refrigeration system that has two (2) temperature range options in refrigerated section. Standard temperature range maintains cabinet temperatures of 33°F to 41°F (5°C to 5°C), ideally suited for refrigerated bakery and cold deli products. Optional temperature range maintains cabinet temperatures of 42°F to 65°F (5.5°C to 18.3°C), ideally suited for chocolate & wine options.
- Pull Out Condensing unit slides out for easy cleaning and maintenance.

CABINET CONSTRUCTION

- Exterior - powder coated FDA black rounded front and back, black aluminum aesthetic side and front panels. Color options available (upcharge may apply) - white or stainless.
- Curved glass front and side glass panels.

- Interior - powder coated FDA white over CRS material. Color options available (upcharge may apply) - black or stainless.
- Insulation - entire cabinet structure is foamed-in-place using a high density, polyurethane insulation that has zero ozone depletion potential (ODP) and zero global warming potential (GWP).
- Welded, heavy duty steel frame rail, black powder coated for corrosion protection.
- Frame rail fitted with leg levelers.

CURVED FRONT DISPLAY GLASS

- Curved glass front and side panels are single pane tempered glass. Front glass opens from closed to fully open to provide extra large viewing area to maximize product presentation while allowing full frontal access.

REAR DOORS

- Two (2) rear sliding glass doors for back access.
- Each door fitted with 12" (305 mm) long aluminum handle.
- Sliding doors ride on stainless steel V-channel with stainless steel bearings. Doors fit within plastic channel frame.

SHELVING

- Six (6) adjustable heavy duty PVC coated wire shelves standard.
- Each shelf supports a maximum weight of 150 lbs. (69 kg).

PAN CAPACITY

- Cabinet holds four (4) 18"L x 26"D (458 mm x 661 mm) display pans and four (4) 12"L x 18"D (305 mm x 458 mm) display pans. Pans supplied by others.

LIGHTING

- LED interior lighting, two (2) clips underneath shelf to keep wires in place. Safety shielded.

MODEL FEATURES

- Refrigerator evaporator is epoxy coated to eliminate the potential of corrosion.
- Front glass swings Up for easy cleaning access.
- Pull out condensing unit slides out for easy cleaning and maintenance.
- Electronic temperature control.
- NSF/ANSI Standard 7 compliant for open food product. Tested and certified for performance at NSF Type II: 80°F (27°C) and 55% relative humidity.

ELECTRICAL

- Unit completely pre-wired at factory and ready for final connection to a 115/60/1 phase, 15 amp dedicated outlet. Cord and plug set included.



OPTIONAL FEATURES/ACCESSORIES

Upcharge and lead times may apply.

- 230 - 240V / 50 Hz.
- White exterior
- Stainless steel exterior
- Custom exterior colors (contact factory for details)
- Black interior
- Stainless steel interior
- Black wire shelves
- Chrome plated wire shelves
- Stainless mezzanine shelves

TDM MODEL NUMBER NOMENCLATURE SYSTEM

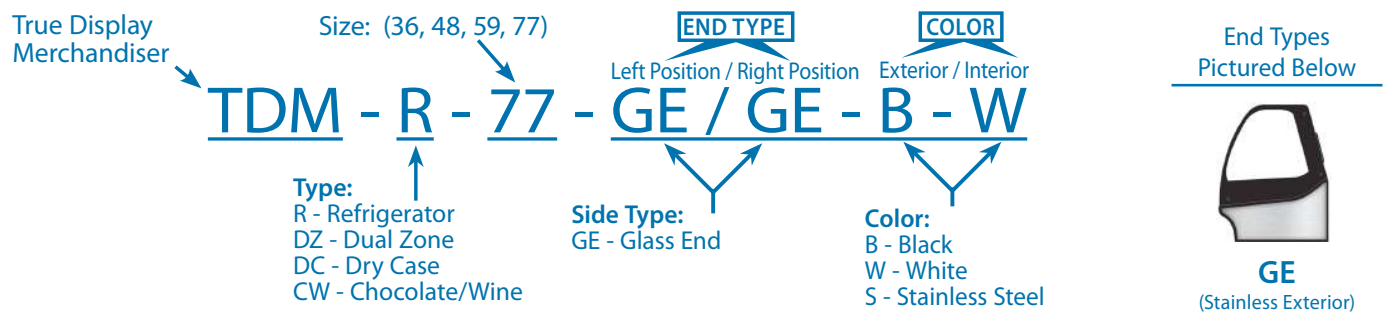

PLAN VIEW

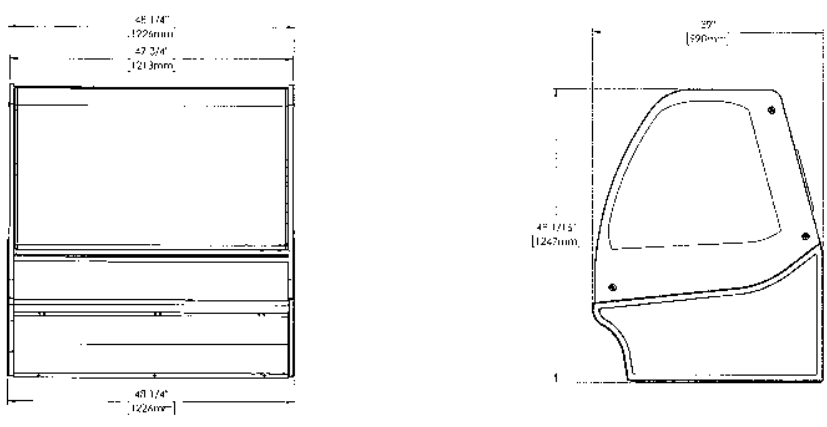

METRIC DIMENSIONS ROUNDED UP TO THE NEAREST WHOLE MILLIMETER
SPECIFICATIONS SUBJECT TO CHANGE WITHOUT NOTICE

	Elevation	Right	Plan	3D	Back

Models TDM-R-48-GE/GE-B-W TDM-R-48-GE/GE-W-W TDM-R-48-GE/GE-S-W TDM-R-48-GE/GE-S-S

True Display Merchandiser

Curved Glass, Glass End Refrigerator



TDM-R-48-GE/GE-B-W



TDM-R-48-GE/GE-W-W



TDM-R-48-GE/GE-S-S



TDM-R-48-GE/GE-B-B (optional black interior)

FEATURES

- ▶ True's refrigerated display merchandisers combine efficient, high volume merchandising and exceptional refrigeration with an elegant curved glass front for sophisticated presentation of high end desserts and pastries.
- ▶ Factory engineered, self-contained, capillary tube system using environmentally friendly R290 hydrocarbon refrigerant that has zero (0) ozone depletion potential (ODP), & 0.02 global warming potential (GWP).
- ▶ High capacity, factory balanced refrigeration system. Standard temperature range maintains cabinet temperatures of 33°F to 41°F (.5°C to 5°C), ideally suited for refrigerated bakery and cold deli products.
- ▶ Cabinet is NSF/ANSI Standard 7 compliant to hold open food product.
- ▶ Two (2) rear sliding glass doors for back access.
- ▶ Exterior - powder coated FDA black rounded front and back, black aluminum aesthetic side and front panels. Color options available (upcharge may apply) - white or stainless. Curved glass front and side glass panels.
- ▶ Interior - powder coated FDA white over CRS material. Color options available (upcharge may apply) - black or stainless.
- ▶ Three (3) tiered levels of adjustable wire cantilever shelves that match cabinet interior color. Chrome plated wire shelves standard on stainless units.
- ▶ Front glass swings Up for easy cleaning access.
- ▶ LED interior lighting provides more even lighting throughout the cabinet. Safety shielded.

STANDARD OPTIONS

Exterior Color	Black, White, or Stainless Steel
Interior Color	Black, White, or Stainless Steel
Glass End (GE)	Clear Glass Interior/Clear Glass Exterior with Black Trim
Shelving	White, Black, Chrome, or Mezzanine

ROUGH-IN DATA

Chart dimensions rounded up to the nearest 1/8" (millimeters rounded up to next whole number). Specifications subject to change without notice.

Model	Doors	Shelves	Cabinet Dimensions (inches)			HP	Voltage	Amps	NEMA Config.	Cord Length (total ft.)	Cord Length (total m)	Crated Weight White/Black Model (lbs.)	Crated Weight Stainless Model (lbs.)
			W	D	H								
TDM-R-48-GE/GE-B-W	2	3	48 1/4	39	49 3/8	1/2	115/60/1	12.0	5-15P	8	2.44	645	TBD
			1226	991	1248	1/2	230-240/50/1	2.9	▲			293	TBD

▲ Represents Exterior/Interior (B-black, W-White, S-Stainless)

▲ Plug type varies by country.

Models:	
TDM-R-48-GE/GE-B-W	TDM-R-48-GE/GE-W-W
TDM-R-48-GE/GE-S-W	TDM-R-48-GE/GE-S-S

True Display Merchandiser: Curved Glass, Glass End Refrigerator



STANDARD FEATURES

DESIGN

- True's refrigerated display case combines efficient, high volume merchandising and exceptional refrigeration with an elegant curved glass front for sophisticated presentation of high end deli, desserts and pastries.
- Designed to provide an attractive companion to our TDM-DC "dry case" display merchandiser. Please note: If units are banked together, because of side panel, a 1/2" gap will remain between units.

REFRIGERATION SYSTEM

- Factory engineered, self-contained, capillary tube system using environmentally friendly R290 hydrocarbon refrigerant that has zero (0) ozone depletion potential (ODP), & 0.02 global warming potential (GWP).
- True's self-cleaning RCU technology eliminates the need to clean the condenser coil, reduces energy consumption and helps maintain the coldest temperatures and freshest product.
- High capacity, factory balanced refrigeration system that has two (2) temperature range options. Standard temperature range maintains cabinet temperatures of 33°F to 41°F (5°C to 5°C), ideally suited for refrigerated bakery and cold deli products. Optional temperature range maintains cabinet temperatures of 42°F to 65°F (5.5°C to 18.3°C), ideally suited for chocolate & wine options.
- Pull Out Condensing unit slides out for easy cleaning and maintenance.

CABINET CONSTRUCTION

- Exterior - powder coated FDA black rounded front and back, black aluminum aesthetic side and front panels. Color options available (upcharge may apply) - white or stainless.
- Curved glass front and side glass panels.

- Interior - powder coated FDA white over CRS material. Color options available (upcharge may apply) - black or stainless.
- Insulation - entire cabinet structure is foamed-in-place using a high density, polyurethane insulation that has zero ozone depletion potential (ODP) and zero global warming potential (GWP).
- Welded, heavy duty steel frame rail, black powder coated for corrosion protection.
- Frame rail fitted with leg levelers.

CURVED FRONT DISPLAY GLASS

- Curved glass front and side panels are single pane tempered glass. Front glass opens from closed to fully open to provide extra large viewing area to maximize product presentation while allowing full frontal access.

REAR DOORS

- Two (2) rear sliding glass doors for back access.
- Each door fitted with 12" (305 mm) long aluminum handle.
- Sliding doors ride on stainless steel V-channel with stainless steel bearings. Doors fit within plastic channel frame.

SHELVING

- Three (3) adjustable heavy duty PVC coated wire shelves standard.
- Each shelf supports a maximum weight of 150 lbs. (69 kg).

PAN CAPACITY

- Cabinet holds four (4) 18"L x 26"D (458 mm x 661 mm) display pans, two (2) 9"L x 26"D (229 mm x 661 mm) display pans and six (6) 12"L x 18"D (305 mm x 458 mm) display pans. Pans supplied by others.

LIGHTING

- LED interior lighting, two (2) clips underneath shelf to keep wires in place. Safety shielded.

MODEL FEATURES

- Evaporator is epoxy coated to eliminate the potential of corrosion.
- Front glass swings Up for easy cleaning access.
- Pull out condensing unit slides out for easy cleaning and maintenance.
- Electronic temperature control.
- NSF/ANSI Standard 7 compliant for open food product. Tested and certified for performance at NSF Type II: 80°F (27°C) and 55% relative humidity.

ELECTRICAL

- Unit completely pre-wired at factory and ready for final connection to a 115/60/1 phase, 15 amp dedicated outlet. Cord and plug set included.



115/60/1
NEMA-5-15R

OPTIONAL FEATURES/ACCESSORIES

Upcharge and lead times may apply.

- 230 - 240V / 50 Hz.
- White exterior
- Stainless steel exterior
- Custom exterior colors (contact factory for details)
- Black interior
- Stainless steel interior
- Black wire shelves
- Chrome plated wire shelves
- Stainless mezzanine shelves

TDM MODEL NUMBER NOMENCLATURE SYSTEM

True Display Merchandiser

Size: (36, 48, 59, 77)

TDM - R - 77 - GE / GE - B - W

Type:
R - Refrigerator
DZ - Dual Zone
DC - Dry Case
CW - Chocolate/Wine

Side Type:
GE - Glass End

Color:
B - Black
W - White
S - Stainless Steel

End Types
Pictured Below



GE
(Stainless Exterior)

PLAN VIEW

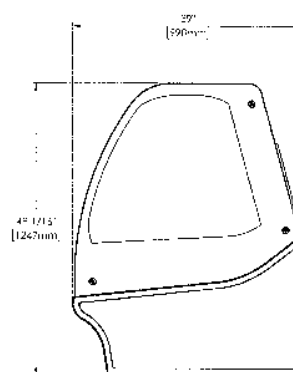
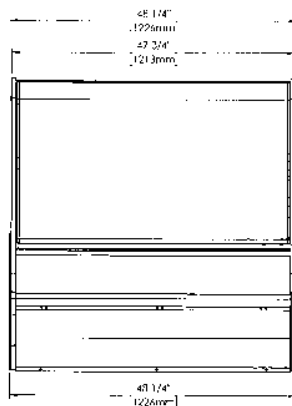

METRIC DIMENSIONS ROUNDED UP TO THE NEAREST WHOLE MILLIMETER

SPECIFICATIONS SUBJECT TO CHANGE WITHOUT NOTICE

	Elevation	Right	Plan	3D	Back

Models TGM-DC-48-SC/SC-B-W TGM-DC-48-SC/SC-W-W TGM-DC-48-SC/SC-S-W TGM-DC-48-SC/SC-S-S

True Glass Merchandiser

Curved Glass, Solid Colored End Refrigerator



TGM-DC-48-SC/SC-B-W



TGM-DC-48-SC/SC-W-W



TGM-DC-48-SC/SC-S-W



TGM-DC-48-SC/SC-S-S

FEATURES

- ▶ True's "dry" glass merchandisers combines efficient, high volume merchandising with an elegant curved glass front for sophisticated presentation of high end desserts and pastries.
- ▶ Cabinet is NSF/ANSI Standard 2 compliant to hold open food product.
- ▶ Two (2) rear sliding glass doors for back access.
- ▶ Exterior - powder coated FDA black rounded front and back, solid wood sides with aluminum cover and front panels. Color options available (upcharge may apply) - white or stainless.
- ▶ Interior - powder coated FDA white over CRS material. Color options available (upcharge may apply) - black or stainless.
- ▶ Three (3) tiered levels of adjustable wire cantilever shelves that match cabinet interior color. Chrome plated wire shelves standard on stainless units.
- ▶ Curved glass front is single pane tempered glass with extra large viewing area to maximize product presentation.
- ▶ LED interior lighting provides more even lighting throughout the cabinet. Safety shielded.

STANDARD OPTIONS

Exterior Color	Black, White, or Stainless Steel
Interior Color	Black, White, or Stainless Steel
Shelving	White, Black, Chrome, or Mezzanine

ROUGH-IN DATA

Specifications subject to change without notice. Chart dimensions rounded up to the nearest 1/8" (millimeters rounded up to next whole number).

Model	Rear Doors	Shelves	Cabinet Dimensions (inches) (mm)			Voltage	Amps	NEMA Config.	Cord Length (total ft.) (total m)	Crated Weight White/Black Model (lbs.) (kg)	Crated Weight Stainless Model (lbs.) (kg)
			W	D	H						
TGM-DC-48-SC/SC-Δ-Δ	2	6	48 1/4 1226	39 990	49 1/8 1247	115/60/1 220-240V/50-60Hz	7.0 0.1	5-15P ▲	9 2.74	TBD TBD	TBD TBD

Δ Represents Exterior/Interior (B-black, W-White, S-Stainless)

▲ Plug type varies by country.

Models:	
TGM-DC-48-SC/SC-B-W	TGM-DC-48-SC/SC-W-W
TGM-DC-48-SC/SC-S-W	TGM-DC-48-SC/SC-S-S

True Glass Merchandiser:

Curved Glass, Solid Colored End Refrigerator



STANDARD FEATURES

DESIGN

- True's dry display case glass merchandiser combines efficient, high volume merchandising and exceptional refrigeration with an elegant curved glass front for sophisticated presentation of high end deli, desserts and pastries.
- Designed to provide an attractive companion to our TGM-R "refrigerated" glass merchandiser. Please note: If units are banked together, because of side panel, a 1/2" (13mm) gap will remain between units.

CABINET CONSTRUCTION

- Exterior - powder coated FDA black rounded front and back, solid wood sides with aluminum cover and front panels. Color options available (upcharge may apply) - white or stainless.
- Curved glass front and side glass panels.
- Interior - powder coated FDA white over CRS material. Color options available (upcharge may apply) - black or stainless.
- Insulation - entire cabinet structure is foamed-in-place using a high density, polyurethane insulation that has zero ozone depletion potential (ODP) and zero global warming potential (GWP).
- Welded, heavy duty steel frame rail, black powder coated for corrosion protection.
- Frame rail fitted with leg levelers.

CURVED FRONT DISPLAY GLASS

- Curved glass front is single pane tempered glass with extra large viewing area to maximize product presentation.

REAR DOORS

- Two (2) rear sliding glass doors for back access.

- Each door fitted with 12" (305 mm) long aluminum handle.
- Sliding doors ride on stainless steel V-channel with stainless steel bearings. Doors fit within plastic channel frame.

SHELVING

- Six (6) adjustable heavy duty PVC coated wire shelves standard.
- Each shelf supports a maximum weight of 150 lbs. (69 kg).

PAN CAPACITY

- Cabinet holds four (4) 18"L x 26"D (458 mm x 661 mm) display pans, two (2) 9"L x 26"D (229 mm x 661 mm) display pans and six (6) 12"L x 18"D (305 mm x 458 mm) display pans. Pans supplied by others.

LIGHTING

- LED interior lighting, two (2) clips underneath shelf to keep wires in place. Safety shielded.

MODEL FEATURES

- NSF/ANSI Standard 2 compliant for open food product.

ELECTRICAL

- Unit completely pre-wired at factory and ready for final connection to a 115/60/1 phase, 15 amp dedicated outlet. Cord and plug set included.



STANDARD OPTIONS

- Upcharge and lead times may apply.
- Black exterior
 - White exterior
 - Stainless steel exterior
 - White interior
 - Black interior
 - Stainless steel interior
 - Solid Colored Exterior Sides with color matching interior (SC)
 - White wire shelves
 - Black wire shelves
 - Chrome plated wire shelves
 - Stainless steel mezzanine shelves
- #### OPTIONAL FEATURES/ACCESSORIES
- Upcharge and lead times may apply.
- 220-240V/50-60Hz
 - Custom exterior colors (contact factory for details)
 - Glass shelves
 - Frosted glass shelves
 - Ratchet lock
 - Electrical Receptacle
 - Exterior top scale shelf
 - Exterior small top service shelf
 - Exterior medium top service shelf
 - Exterior large top service shelf
 - External front shelf kit (only available in black)
 - External rear service shelf shelf kit (only available in black)
 - 4" (102mm) Castors
 - 2 1/2" (64mm) castors
 - 6" (153mm) legs

TGM MODEL NUMBER NOMENCLATURE SYSTEM

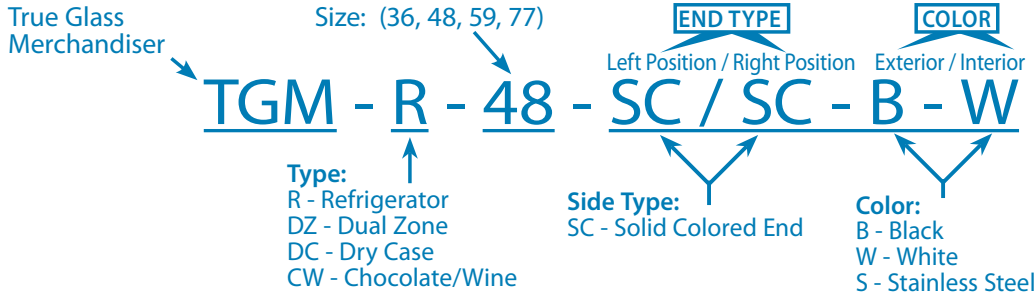

PLAN VIEW

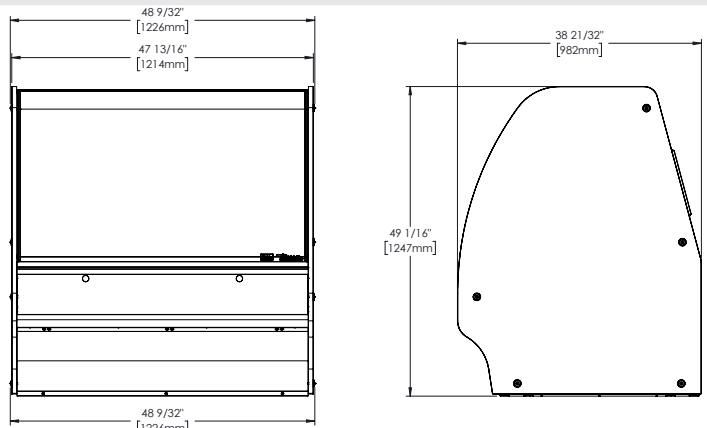

METRIC DIMENSIONS ROUNDED UP TO THE NEAREST WHOLE MILLIMETER
SPECIFICATIONS SUBJECT TO CHANGE WITHOUT NOTICE

	Elevation	Right	Plan	3D	Back

Models TGM-DZ-48-SC/SC-B-W TGM-DZ-48-SC/SC-W-W TGM-DZ-48-SC/SC-S-W TGM-DZ-48-SC/SC-S-S

True Glass Merchandiser

Curved Glass, Solid Colored End Dual Zone



TGM-DZ-48-SC/SC-B-W



TGM-DZ-48-SC/SC-W-W



TGM-DZ-48-SC/SC-S-W



TGM-DZ-48-SC/SC-S-S

FEATURES

- ▶ True's dual zone glass merchandisers combine efficient, high volume merchandising and exceptional refrigeration with an elegant curved glass front for sophisticated presentation of high end desserts and pastries.
- ▶ Factory engineered, self-contained, capillary tube system using environmentally friendly R290 hydrocarbon refrigerant that has zero (0) ozone depletion potential (ODP), & 0.02 global warming potential (GWP).
- ▶ Refrigerated section features high capacity, factory balanced refrigeration system. Standard temperature range maintains cabinet temperatures of 33°F to 41°F (5°C to 5°C), ideally suited for refrigerated bakery and cold deli products.
- ▶ Two (2) rear sliding glass doors for back access.
- ▶ Exterior - powder coated FDA black rounded front and back, solid wood sides with aluminum cover and front panels. Color options available (upcharge may apply) - white or stainless.
- ▶ Interior - powder coated FDA white over CRS material. Color options available (upcharge may apply) - black or stainless.
- ▶ Three (3) tiered levels of adjustable wire cantilever shelves that match cabinet interior color. Chrome plated wire shelves standard on stainless units.
- ▶ Curved glass front is single pane tempered glass with extra large viewing area to maximize product presentation.
- ▶ LED interior lighting provides more even lighting throughout the cabinet. Safety shielded.

STANDARD OPTIONS

Exterior Color	Black, White, or Stainless Steel
Interior Color	Black, White, or Stainless Steel
Shelving	White, Black, Chrome, or Mezzanine

ROUGH-IN DATA

Specifications subject to change without notice. Chart dimensions rounded up to the nearest 1/8" (millimeters rounded up to next whole number).

Model	Doors	Shelves	Cabinet Dimensions (inches) (mm)			HP	Voltage	Amps	NEMA Config.	Cord Length (total ft.) (total m)	Crated Weight White/Black Model (lbs.) (kg)	Crated Weight Stainless Model (lbs.) (kg)
			W	D	H							
TGM-DZ-48-SC/SC-Δ-Δ	2	6	48 1/4	39	49 3/8	1/4	115/60/1	10.0	5-15P	8	TBD	TBD
			1226	990	1247	1/4	220-240V/50Hz	2.0	▲	2.44	TBD	TBD
						1/4	220V/60Hz	2.3	▲			

Δ Represents Exterior/Interior (B-black, W-White, S-Stainless)

▲ Plug type varies by country.

Models:	
TGM-DZ-48-SC/SC-B-W	TGM-DZ-48-SC/SC-W-W
TGM-DZ-48-SC/SC-S-W	TGM-DZ-48-SC/SC-S-S

True Glass Merchandiser:

Curved Glass, Solid Colored End Dual Zone



STANDARD FEATURES

DESIGN

- True's combination "refrigerated" and "dry" display case glass merchandiser combines efficient, high volume merchandising and exceptional refrigeration with an elegant curved glass front for sophisticated presentation of high end end deli, desserts and pastries.
- Please note: If units are banked together, because of side panel, a 1/2" (13mm) gap will remain between units.

REFRIGERATION SYSTEM

- Factory engineered, self-contained, capillary tube system using environmentally friendly R290 hydrocarbon refrigerant that has zero (0) ozone depletion potential (ODP), & 0.02 global warming potential (GWP).
- True's self-cleaning RCU technology eliminates the need to clean the condenser coil, reduces energy consumption and helps maintain the coldest temperatures and freshest product.
- High capacity, factory balanced refrigeration system that has two (2) temperature range options. Standard temperature range maintains cabinet temperatures of 33°F to 41°F (.5°C to 5°C), ideally suited for refrigerated bakery and cold deli products. Optional temperature range maintains cabinet temperatures of 42°F to 65°F (5.5°C to 18.3°C), ideally suited for chocolate & wine options.
- Pull Out Condensing unit slides out for easy cleaning and maintenance.

CABINET CONSTRUCTION

- Exterior - powder coated FDA black rounded front and back, solid wood sides with aluminum cover and front panels. Color options available (upcharge may apply) - white or stainless.
- Curved glass front and side glass panels.
- Interior - powder coated FDA white over CRS material. Color options available (upcharge may apply) - black or stainless.
- Insulation - entire cabinet structure is foamed-in-place using a high density, polyurethane insulation that has zero ozone depletion potential (ODP) and zero global warming potential (GWP).
- Welded, heavy duty steel frame rail, black powder coated for corrosion protection.
- Frame rail fitted with leg levelers.

CURVED FRONT DISPLAY GLASS

- Curved glass front is single pane tempered glass with extra large viewing area to maximize product presentation.

REAR DOORS

- Two (2) rear sliding glass doors for back access.
- Each door fitted with 12" (305 mm) long aluminum handle.
- Sliding doors ride on stainless steel V-channel with stainless steel bearings. Doors fit within plastic channel frame.

SHELVING

- Six (6) adjustable heavy duty PVC coated wire shelves standard.
- Each shelf supports a maximum weight of 150 lbs. (69 kg).

PAN CAPACITY

- Cabinet holds four (4) 18"L x 26"D (458 mm x 661 mm) display pans, two (2) 9"L x 26"D (229 mm x 661 mm) display pans and six (8) 12"L x 18"D (305 mm x 458 mm) display pans. Pans supplied by others.

LIGHTING

- LED interior lighting, two (2) clips underneath shelf to keep wires in place. Safety shielded.

MODEL FEATURES

- Evaporator is epoxy coated to eliminate the potential of corrosion.
- Pull out condensing unit slides out for easy cleaning and maintenance.
- Electronic temperature control.
- NSF/ANSI Standard 7 compliant for open food product. Tested and certified for performance at NSF Type II: 80°F (27°C) and 55% relative humidity.

ELECTRICAL

- Unit completely pre-wired at factory and ready for final connection to a 115/60/1 phase, 15 amp dedicated outlet. Cord and plug set included.



STANDARD OPTIONS

Upcharge and lead times may apply.

- Black exterior
- White exterior
- Stainless steel exterior
- White interior
- Black interior
- Stainless steel interior
- Solid Colored Exterior Sides with color matching interior (SC)
- White wire shelves
- Black wire shelves
- Chrome plated wire shelves
- Stainless steel mezzanine shelves

OPTIONAL FEATURES/ACCESSORIES

Upcharge and lead times may apply.

- 220-240V/50Hz
- 220V/60Hz
- Custom exterior colors (contact factory for details)
- Chocolate/Wine model available
- Glass shelves
- Frosted glass shelves
- Ratchet lock
- Electrical Receptacle
- Exterior top scale shelf
- Exterior small top service shelf
- Exterior medium top service shelf
- Exterior large top service shelf
- External front shelf kit (only available in black)
- External rear service shelf kit (only available in black)
- 4" (102mm) Castors
- 2 1/2" (64mm) castors
- 6" (153mm) legs

TGM MODEL NUMBER NOMENCLATURE SYSTEM

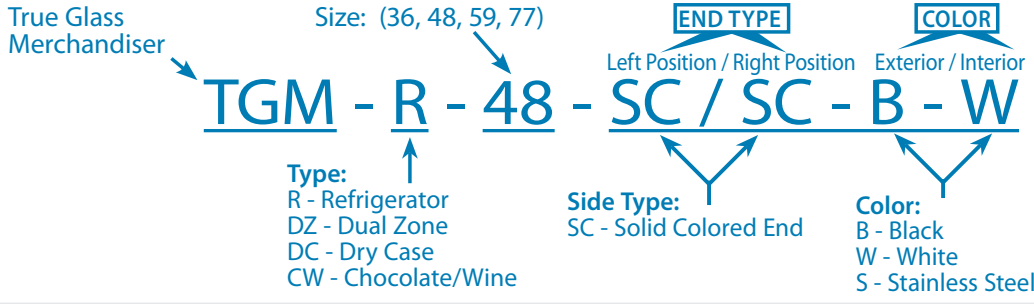

Note: Dual Zone models Not Available in 36 size models.

PLAN VIEW

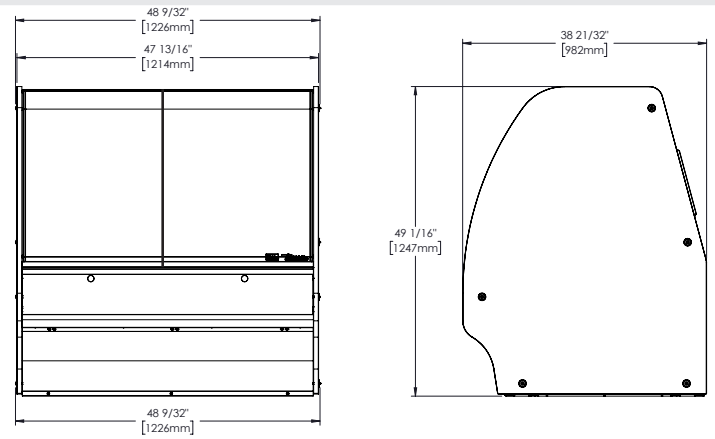

METRIC DIMENSIONS ROUNDED UP TO THE NEAREST WHOLE MILLIMETER
SPECIFICATIONS SUBJECT TO CHANGE WITHOUT NOTICE

	Elevation	Right	Plan	3D	Back

Models TGM-R-48-SC/SC-B-W TGM-R-48-SC/SC-W-W TGM-R-48-SC/SC-S-W TGM-R-48-SC/SC-S-S

True Glass Merchandiser

Curved Glass, Solid Colored End Refrigerator



TGM-R-48-SC/SC-B-W



TGM-R-48-SC/SC-W-W



TGM-R-48-SC/SC-S-W



TGM-R-48-SC/SC-S-S

FEATURES

- ▶ True's refrigerated glass merchandisers combine efficient, high volume merchandising and exceptional refrigeration with an elegant curved glass front for sophisticated presentation of high end desserts and pastries.
- ▶ Factory engineered, self-contained, capillary tube system using environmentally friendly R290 hydrocarbon refrigerant that has zero (0) ozone depletion potential (ODP), & 0.02 global warming potential (GWP).
- ▶ High capacity, factory balanced refrigeration system. Standard temperature range maintains cabinet temperatures of 33°F to 41°F (.5°C to 5°C), ideally suited for refrigerated bakery and cold deli products.
- ▶ Cabinet is NSF/ANSI Standard 7 compliant to hold open food product.
- ▶ Two (2) rear sliding glass doors for back access.
- ▶ Exterior - powder coated FDA black rounded front and back, solid wood sides with aluminum cover and front panels. Color options available (upcharge may apply) - white or stainless.
- ▶ Interior - powder coated FDA white over CRS material. Color options available (upcharge may apply) - black or stainless.
- ▶ Three (3) tiered levels of adjustable wire cantilever shelves that match cabinet interior color. Chrome plated wire shelves standard on stainless units.
- ▶ Curved glass front is single pane tempered glass with extra large viewing area to maximize product presentation.
- ▶ LED interior lighting provides more even lighting throughout the cabinet. Safety shielded.

STANDARD OPTIONS

Exterior Color	Black, White, or Stainless Steel
Interior Color	Black, White, or Stainless Steel
Shelving	White, Black, Chrome, or Mezzanine

ROUGH-IN DATA

Specifications subject to change without notice. Chart dimensions rounded up to the nearest 1/8" (millimeters rounded up to next whole number).

Models	Doors	Shelves	Cabinet Dimensions (inches) (mm)			HP	Voltage	Amps	NEMA Config.	Cord Length (total ft.) (total m)	Crated Weight White/Black Model (lbs.) (kg)	Crated Weight Stainless Model (lbs.) (kg)
			W	D	H							
TGM-R-48-/SC-Δ-Δ	2	6	48 1/4	39	49 3/8	1/2	115/60/1	12.0	5-15P	8	685	TBD
			1226	990	1247	1/2	230-240/50/1	3.0	▲			
						1/2	220/60/1	3.6	▲			

Δ Represents Exterior/Interior (B-black, W-White, S-Stainless).

Models:	
TGM-R-48-SC/SC-B-W	TGM-R-48-SC/SC-W-W
TGM-R-48-SC/SC-S-W	TGM-R-48-SC/SC-S-S

True Glass Merchandiser:

Curved Glass, Solid Colored End Refrigerator



STANDARD FEATURES

- DESIGN**
- True's refrigerated display case glass merchandiser combines efficient, high volume merchandising and exceptional refrigeration with an elegant curved glass front for sophisticated presentation of high end deli, desserts and pastries.
 - Designed to provide an attractive companion to our TGM-DC "dry case" display merchandiser. Please note: If units are banked together, because of side panel, a 1/2" (13mm) gap will remain between units.
- REFRIGERATION SYSTEM**
- Factory engineered, self-contained, capillary tube system using environmentally friendly R290 hydrocarbon refrigerant that has zero (0) ozone depletion potential (ODP), & 0.02 global warming potential (GWP).
 - True's self-cleaning RCU technology eliminates the need to clean the condenser coil, reduces energy consumption and helps maintain the coldest temperatures and freshest product.
 - High capacity, factory balanced refrigeration system that has two (2) temperature range options. Standard temperature range maintains cabinet temperatures of 33°F to 41°F (.5°C to 5°C), ideally suited for refrigerated bakery and cold deli products. Optional temperature range maintains cabinet temperatures of 42°F to 65°F (5.5°C to 18.3°C), ideally suited for chocolate & wine options.
 - Pull Out Condensing unit slides out for easy cleaning and maintenance.
- CABINET CONSTRUCTION**
- Exterior - powder coated FDA black rounded front and back, solid wood sides with aluminum cover and front panels. Color options available (upcharge may apply) - white or stainless.
 - Curved glass front and side glass panels.
 - Interior - powder coated FDA white over CRS material. Color options available (upcharge may apply) - black or stainless.
 - Insulation - entire cabinet structure is foamed-in-place using a high density, polyurethane insulation that has zero ozone depletion potential (ODP) and zero global warming potential (GWP).
 - Welded, heavy duty steel frame rail, black powder coated for corrosion protection.

- Frame rail fitted with leg levelers.
- CURVED FRONT DISPLAY GLASS**
- Curved glass front is single pane tempered glass with extra large viewing area to maximize product presentation.
- REAR DOORS**
- Two (2) rear sliding glass doors for back access.
 - Each door fitted with 12" (305 mm) long aluminum handle.
 - Sliding doors ride on stainless steel V-channel with stainless steel bearings. Doors fit within plastic channel frame.
- SHELVING**
- Six (6) adjustable heavy duty PVC coated wire shelves standard.
 - Each shelf supports a maximum weight of 150 lbs. (69 kg).
- PAN CAPACITY**
- Cabinet holds four (4) 18"L x 26"D (458 mm x 661 mm) display pans, two (2) 9"L x 26"D (229 mm x 661 mm) display pans and six (6) 12"L x 18"D (305 mm x 458 mm) display pans. Pans supplied by others.
- LIGHTING**
- LED interior lighting, two (2) clips underneath shelf to keep wires in place. Safety shielded.
- MODEL FEATURES**
- Evaporator is epoxy coated to eliminate the potential of corrosion.
 - Pull out condensing unit slides out for easy cleaning and maintenance.
 - Electronic temperature control.
 - NSF/ANSI Standard 7 compliant for open food product. Tested and certified for performance at NSF Type II: 80°F (27°C) and 55% relative humidity.
- ELECTRICAL**
- Unit completely pre-wired at factory and ready for final connection to a 115/60/1 phase, 15 amp dedicated outlet. Cord and plug set included.



- STANDARD OPTIONS**
- Upcharge and lead times may apply.
- Black exterior
 - White exterior
 - Stainless steel exterior
 - White interior
 - Black interior
 - Stainless steel interior
 - Solid Colored Exterior Sides with color matching interior (SC)
 - White wire shelves
 - Black wire shelves
 - Chrome plated wire shelves
 - Stainless steel mezzanine shelves
- OPTIONAL FEATURES/ACCESSORIES**
- Upcharge and lead times may apply.
- Custom exterior colors (contact factory for details)
 - Chocolate/Wine model available
 - Glass shelves
 - Frosted glass shelves
 - Ratchet lock
 - Electrical Receptacle
 - Exterior top scale shelf
 - Exterior small top service shelf
 - Exterior medium top service shelf
 - Exterior large top service shelf
 - External front shelf kit (only available in black)
 - External rear service shelf kit (only available in black)
 - 4" (102mm) Castors
 - 2 1/2" (64mm) castors
 - 6" (153mm) legs
 - 230 - 240V / 50 Hz.
 - 220V / 60 Hz.

TGM MODEL NUMBER NOMENCLATURE SYSTEM

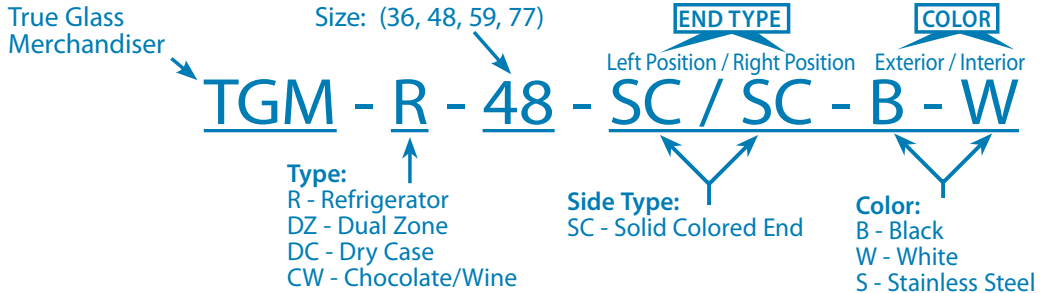

PLAN VIEW

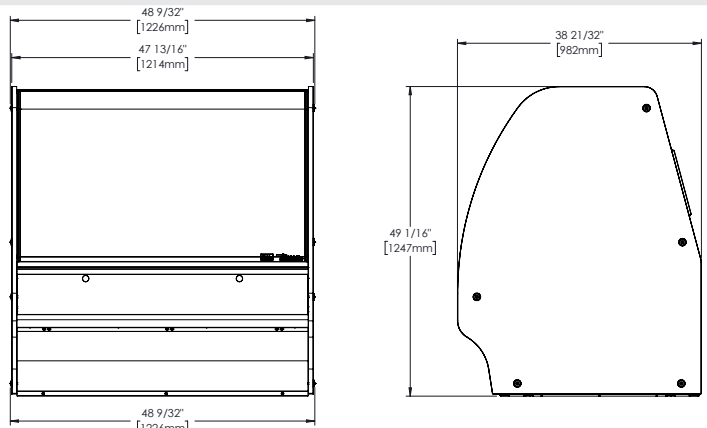

METRIC DIMENSIONS ROUNDED UP TO THE NEAREST WHOLE MILLIMETER
SPECIFICATIONS SUBJECT TO CHANGE WITHOUT NOTICE

	Elevation	Right	Plan	3D	Back

Models TDM-DC-59-GE/GE-B-W TDM-DC-59-GE/GE-W-W TDM-DC-59-GE/GE-S-W TDM-DC-59-GE/GE-S-S

True Display Merchandiser

Curved Glass, Glass End Dry Case



TDM-DC-59-GE/GE-B-W



TDM-DC-59-GE/GE-W-W



TDM-DC-59-GE/GE-S-S



TDM-DC-59-GE/GE-B-B (optional black interior)

FEATURES

- ▶ True's "dry" display case combines efficient, high volume merchandising with an elegant curved glass front for sophisticated presentation of high end desserts and pastries.
- ▶ Cabinet is NSF/ANSI Standard 2 compliant to hold open food product.
- ▶ Two (2) rear sliding glass doors for back access.
- ▶ Exterior - powder coated FDA black rounded front and back, black aluminum aesthetic side and front panels. Color options available (upcharge may apply) - white or stainless. Curved glass front and side glass panels.
- ▶ Interior - powder coated FDA white over CRS material. Color options available (upcharge may apply) - black or stainless.
- ▶ Three (3) tiered levels of adjustable wire cantilever shelves that match cabinet interior color. Chrome plated wire shelves standard on stainless units.
- ▶ Front glass swings Up for easy cleaning access.
- ▶ LED interior lighting provides more even lighting throughout the cabinet. Safety shielded.

STANDARD OPTIONS

Exterior Color	Black, White, or Stainless Steel
Interior Color	Black, White, or Stainless Steel
Glass End (GE)	Clear Glass Interior/Clear Glass Exterior with Black Trim
Shelving	White, Black, Chrome, or Mezzanine

ROUGH-IN DATA

Specifications subject to change without notice. Chart dimensions rounded up to the nearest 1/8" (millimeters rounded up to next whole number).

Model	Doors	Shelves	Cabinet Dimensions (inches) (mm)			Voltage	Amps	NEMA Config.	Cord Length (total ft.) (total m)	Crated Weight White/Black Model (lbs.) (kg)	Crated Weight Stainless Model (lbs.) (kg)
			W	D	H						
TDM-DC-59-GE/GE-Δ-Δ	2	3	59 1/4 1505	39 991	49 3/8 1248	115/60/1 220-240V/50Hz 220V/60Hz	7.0 0.2 0.2	5-15P ▲ ▲	8 2.44	665 302	TBD TBD

Δ Represents Exterior/Interior (B-black, W-White, S-Stainless)

▲ Plug type varies by country.

Models:		True Display Merchandiser: <i>Curved Glass, Glass End Dry Case</i>	
TDM-DC-59-GE/GE-B-W	TDM-DC-59-GE/GE-W-W		
TDM-DC-59-GE/GE-S-W	TDM-DC-59-GE/GE-S-S		

STANDARD FEATURES

DESIGN

- True's "dry" display case combines efficient, high volume merchandising with an elegant curved glass front for sophisticated presentation of high end desserts and pastries.
- Designed to provide an attractive companion to our TDM-R "refrigerated" display merchandiser. Please note: If units are banked together, because of side panel, a 1/2" gap will remain between units.

CABINET CONSTRUCTION

- Exterior - powder coated FDA black rounded front and back, black aluminum aesthetic side and front panels. Color options available (upcharge may apply) - white or stainless.
- Curved glass front and side glass panels.
- Interior - powder coated FDA white over CRS material. Color options available (upcharge may apply) - black or stainless.
- Insulation - entire cabinet structure is foamed-in-place using a high density, polyurethane insulation that has zero ozone depletion potential (ODP) and 0.02 global warming potential (GWP).
- Welded, heavy duty steel frame rail, black powder coated for corrosion protection.
- Frame rail fitted with leg levelers.

CURVED FRONT DISPLAY GLASS

- Curved glass front and side panels are single pane tempered glass. Front glass opens from closed to fully open to provide extra large viewing area to maximize product presentation while allowing full frontal access.

REAR DOORS

- Two (2) rear sliding glass doors for back access.
- Each door fitted with 12" (305 mm) long aluminum handle.
- Sliding doors ride on stainless steel V-channel with stainless steel bearings. Doors fit within plastic channel frame.

SHELVING

- Three (3) adjustable heavy duty PVC coated wire shelves standard.
- Each shelf supports a maximum weight of 150 lbs. (69 kg).

PAN CAPACITY

- Cabinet holds six (6) 18"L x 26"D (458 mm x 661 mm) display pans and eight (8) 12"L x 18"D (305 mm x 458 mm) display pans. Pans supplied by others.

LIGHTING

- LED interior lighting, two (2) clips underneath shelf to keep wires in place. Safety shielded.

MODEL FEATURES

- Front glass swings Up for easy cleaning access.
- NSF/ANSI Standard 2 compliant for open food product.

ELECTRICAL

- Unit completely pre-wired at factory and ready for final connection to a 115/60/1 phase, 15 amp dedicated outlet. Cord and plug set included.



OPTIONAL FEATURES/ACCESSORIES

Upcharge and lead times may apply.

- 220-240V/50Hz
- 220V/60Hz
- White exterior
- Stainless steel exterior
- Custom exterior colors (contact factory for details)
- Black interior
- Stainless steel interior
- Black wire shelves
- Chrome plated wire shelves
- Stainless mezzanine shelves

TDM MODEL NUMBER NOMENCLATURE SYSTEM

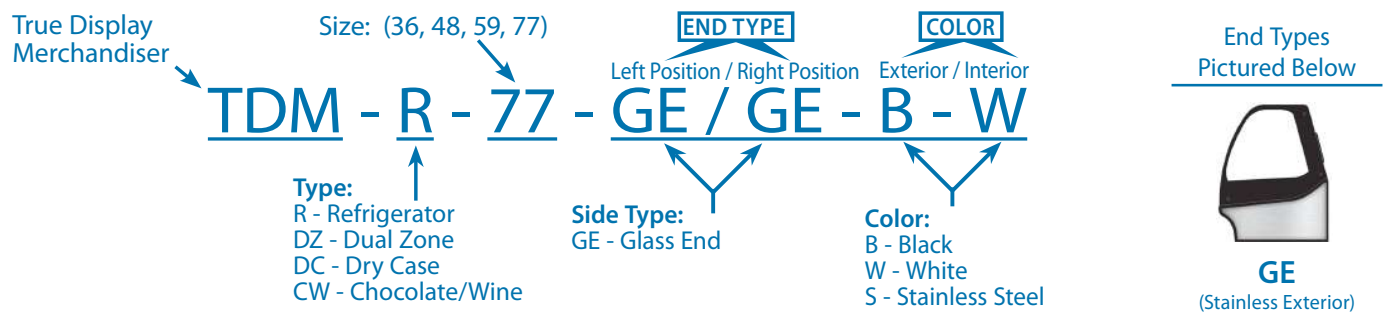

PLAN VIEW

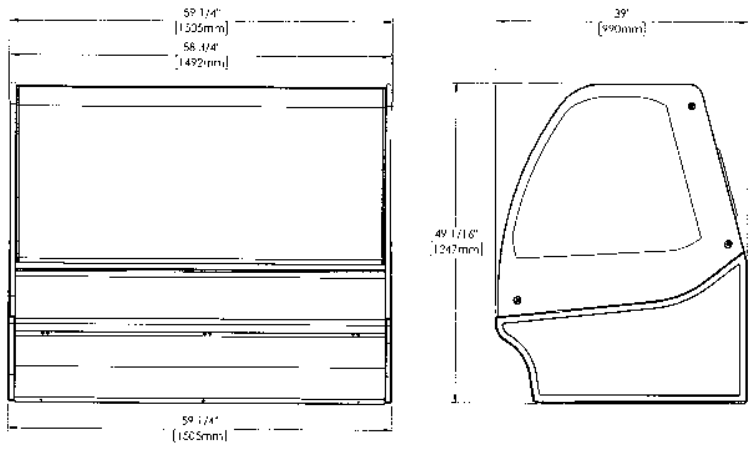

METRIC DIMENSIONS ROUNDED UP TO THE NEAREST WHOLE MILLIMETER
SPECIFICATIONS SUBJECT TO CHANGE WITHOUT NOTICE

	Elevation	Right	Plan	3D	Back

Models TDM-DZ-59-GE/GE-B-W TDM-DZ-59-GE/GE-W-W TDM-DZ-59-GE/GE-S-W TDM-DZ-59-GE/GE-S-S

True Display Merchandiser

Curved Glass, Glass End Dual Zone



TDM-DZ-59-GE/GE-B-W



TDM-DZ-59-GE/GE-W-W



TDM-DZ-59-GE/GE-S-S



TDM-DZ-59-GE/GE-B-B (optional black interior)

FEATURES

- ▶ True's refrigerated display merchandisers combine efficient, high volume merchandising and exceptional refrigeration with an elegant curved glass front for sophisticated presentation of high end desserts and pastries.
- ▶ Factory engineered, self-contained, capillary tube system using environmentally friendly R290 hydrocarbon refrigerant that has zero (0) ozone depletion potential (ODP), & 0.02 global warming potential (GWP).
- ▶ Refrigerated section features high capacity, factory balanced refrigeration system. Standard temperature range maintains cabinet temperatures of 33°F to 41°F (.5°C to 5°C), ideally suited for refrigerated bakery and cold deli products.
- ▶ Cabinet is NSF/ANSI Standard 7 compliant to hold open food product.
- ▶ Two (2) rear sliding glass doors for back access.
- ▶ Exterior - powder coated FDA black rounded front and back, black aluminum aesthetic side and front panels. Color options available (upcharge may apply) - white or stainless. Curved glass front and side glass panels.
- ▶ Interior - powder coated FDA white over CRS material. Color options available (upcharge may apply) - black or stainless.
- ▶ Six (6) tiered levels of adjustable wire cantilever shelves that match cabinet interior color. Chrome plated wire shelves standard on stainless units.
- ▶ Front glass swings Up for easy cleaning access.
- ▶ LED interior lighting provides more even lighting throughout the cabinet. Safety shielded.

STANDARD OPTIONS

Exterior Color	Black, White, or Stainless Steel
Interior Color	Black, White, or Stainless Steel
Glass End (GE)	Clear Glass Interior/Clear Glass Exterior with Black Trim
Shelving	White, Black, Chrome, or Mezzanine

ROUGH-IN DATA

Specifications subject to change without notice. Chart dimensions rounded up to the nearest 1/8" (millimeters rounded up to next whole number).

Model	Doors	Shelves	Cabinet Dimensions (inches) (mm)				HP	Voltage	Amps	NEMA Config.	Cord Length (total ft.) (total m)	Crated Weight White/Black Model (lbs.) (kg)	Crated Weight Stainless Model (lbs.) (kg)
			W	D	H								
TDM-DZ-59-GE/GE-Δ-Δ	2	6	59 1/4 1505	39 991	49 3/8 1248	1/4 1/4	115/60/1 230-240/50/1	10.0 1.8	5-15P ▲	8 2.44	770 350	TBD TBD	

Δ Represents Exterior/Interior (B-black, W-White, S-Stainless)

▲ Plug type varies by country.

Models:	
TDM-DZ-59-GE/GE-B-W	TDM-DZ-59-GE/GE-W-W
TDM-DZ-59-GE/GE-S-W	TDM-DZ-59-GE/GE-S-S

True Display Merchandiser: Curved Glass, Glass End Dual Zone



STANDARD FEATURES

DESIGN

- True's combination "refrigerated" and "dry" display case combines efficient, high volume merchandising and exceptional refrigeration with an elegant curved glass front for sophisticated presentation of high end deli, desserts and pastries.
- Please note: If units are banked together, because of side panel, a 1/2" gap will remain between units.

REFRIGERATION SYSTEM

- Factory engineered, self-contained, capillary tube system using environmentally friendly R290 hydrocarbon refrigerant that has zero (0) ozone depletion potential (ODP), & 0.02 global warming potential (GWP).
- True's self-cleaning RCU technology eliminates the need to clean the condenser coil, reduces energy consumption and helps maintain the coldest temperatures and freshest product.
- High capacity, factory balanced refrigeration system that has two (2) temperature range options in refrigerated section. Standard temperature range maintains cabinet temperatures of 33°F to 41°F (.5°C to 5°C), ideally suited for refrigerated bakery and cold deli products. Optional temperature range maintains cabinet temperatures of 42°F to 65°F (5.5°C to 18.3°C), ideally suited for chocolate & wine options.
- Pull Out Condensing unit slides out for easy cleaning and maintenance.

CABINET CONSTRUCTION

- Exterior - powder coated FDA black rounded front and back, black aluminum aesthetic side and front panels. Color options available (upcharge may apply) - white or stainless.
- Curved glass front and side glass panels.

- Interior - powder coated FDA white over CRS material. Color options available (upcharge may apply) - black or stainless.
- Insulation - entire cabinet structure is foamed-in-place using a high density, polyurethane insulation that has zero ozone depletion potential (ODP) and zero global warming potential (GWP).
- Welded, heavy duty steel frame rail, black powder coated for corrosion protection.
- Frame rail fitted with leg levelers.

CURVED FRONT DISPLAY GLASS

- Curved glass front and side panels are single pane tempered glass. Front glass opens from closed to fully open to provide extra large viewing area to maximize product presentation while allowing full frontal access.

REAR DOORS

- Two (2) rear sliding glass doors for back access.
- Each door fitted with 12" (305 mm) long aluminum handle.
- Sliding doors ride on stainless steel V-channel with stainless steel bearings. Doors fit within plastic channel frame.

SHELVING

- Six (6) adjustable heavy duty PVC coated wire shelves standard.
- Each shelf supports a maximum weight of 150 lbs. (69 kg).

PAN CAPACITY

- Cabinet holds eight (8) 18"L x 26"D (458 mm x 661 mm) display pans and four (4) 9"L x 26"D (229 mm x 661 mm) display pans. Pans supplied by others.

LIGHTING

- LED interior lighting, two (2) clips underneath shelf to keep wires in place. Safety shielded.

MODEL FEATURES

- Refrigerator evaporator is epoxy coated to eliminate the potential of corrosion.
- Front glass swings Up for easy cleaning access.
- Pull out condensing unit slides out for easy cleaning and maintenance.
- Electronic temperature control.
- NSF/ANSI Standard 7 compliant for open food product. Tested and certified for performance at NSF Type II: 80°F (27°C) and 55% relative humidity.

ELECTRICAL

- Unit completely pre-wired at factory and ready for final connection to a 115/60/1 phase, 15 amp dedicated outlet. Cord and plug set included.



OPTIONAL FEATURES/ACCESSORIES
Upcharge and lead times may apply.

- 230 - 240V / 50 Hz.
- White exterior
- Stainless steel exterior
- Custom exterior colors (contact factory for details)
- Black interior
- Stainless steel interior
- Black wire shelves
- Chrome plated wire shelves
- Stainless mezzanine shelves

TDM MODEL NUMBER NOMENCLATURE SYSTEM

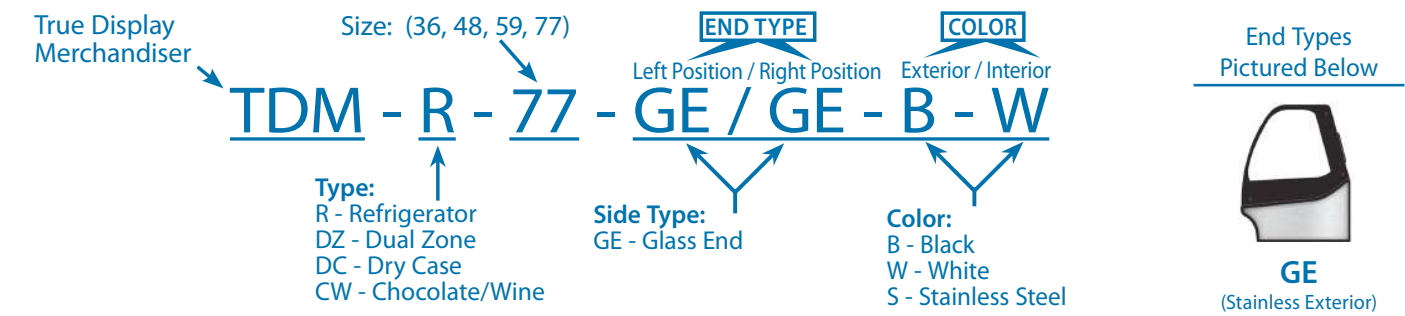

PLAN VIEW

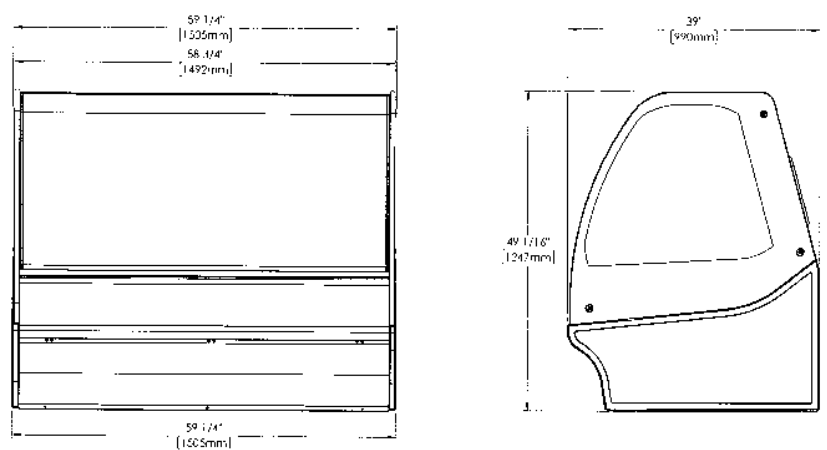

METRIC DIMENSIONS ROUNDED UP TO THE NEAREST WHOLE MILLIMETER
SPECIFICATIONS SUBJECT TO CHANGE WITHOUT NOTICE

	Elevation	Right	Plan	3D	Back

Models TDM-R-59-GE/GE-B-W TDM-R-59-GE/GE-W-W TDM-R-59-GE/GE-S-W TDM-R-59-GE/GE-S-S

True Display Merchandiser

Curved Glass, Glass End Refrigerator



TDM-R-59-GE/GE-B-W



TDM-R-59-GE/GE-W-W



TDM-R-59-GE/GE-S-S



TDM-R-59-GE/GE-B-B (optional black interior)

FEATURES

- ▶ True's refrigerated display merchandisers combine efficient, high volume merchandising and exceptional refrigeration with an elegant curved glass front for sophisticated presentation of high end desserts and pastries.
- ▶ Factory engineered, self-contained, capillary tube system using environmentally friendly R290 hydrocarbon refrigerant that has zero (0) ozone depletion potential (ODP), & 0.02 global warming potential (GWP).
- ▶ High capacity, factory balanced refrigeration system. Standard temperature range maintains cabinet temperatures of 33°F to 41°F (.5°C to 5°C), ideally suited for refrigerated bakery and cold deli products.
- ▶ Cabinet is NSF/ANSI Standard 7 compliant to hold open food product.
- ▶ Two (2) rear sliding glass doors for back access.
- ▶ Exterior - powder coated FDA black rounded front and back, black aluminum aesthetic side and front panels. Color options available (upcharge may apply) - white or stainless. Curved glass front and side glass panels.
- ▶ Interior - powder coated FDA white over CRS material. Color options available (upcharge may apply) - black or stainless.
- ▶ Three (3) tiered levels of adjustable wire cantilever shelves that match cabinet interior color. Chrome plated wire shelves standard on stainless units.
- ▶ Front glass swings Up for easy cleaning access.
- ▶ LED interior lighting provides more even lighting throughout the cabinet. Safety shielded.

STANDARD OPTIONS

Exterior Color	Black, White, or Stainless Steel
Interior Color	Black, White, or Stainless Steel
Glass End (GE)	Clear Glass Interior/Clear Glass Exterior with Black Trim
Shelving	White, Black, Chrome, or Mezzanine

ROUGH-IN DATA

Specifications subject to change without notice. Chart dimensions rounded up to the nearest 1/8" (millimeters rounded up to next whole number).

Model	Doors	Shelves	Cabinet Dimensions (inches) (mm)				HP	Voltage	Amps	NEMA Config.	Cord Length (total ft.) (total m)	Crated Weight White/Black Model (lbs.) (kg)	Crated Weight Stainless Model (lbs.) (kg)
			W	D	H								
TDM-R-59-GE/GE-Δ-Δ	2	3	59 1/4 1505	39 991	49 7/8 1248	1/2 1/2	115/60/1 230-240/50/1	12.0 3.1	5-15P ▲	8 2.44	760 345	TBD TBD	

Δ Represents Exterior/Interior (B-black, W-White, S-Stainless)

▲ Plug type varies by country.

Models:		True Display Merchandiser:	
TDM-R-59-GE/GE-B-W	TDM-R-59-GE/GE-W-W	Curved Glass, Glass End Refrigerator	
TDM-R-59-GE/GE-S-W	TDM-R-59-GE/GE-S-S		

STANDARD FEATURES

DESIGN

- True's refrigerated display case combines efficient, high volume merchandising and exceptional refrigeration with an elegant curved glass front for sophisticated presentation of high end deli, desserts and pastries.
- Designed to provide an attractive companion to our TDM-DC "dry case" display merchandiser. Please note: If units are banked together, because of side panel, a 1/2" gap will remain between units.

REFRIGERATION SYSTEM

- Factory engineered, self-contained, capillary tube system using environmentally friendly R290 hydrocarbon refrigerant that has zero (0) ozone depletion potential (ODP), & 0.02 global warming potential (GWP).
- True's self-cleaning RCU technology eliminates the need to clean the condenser coil, reduces energy consumption and helps maintain the coldest temperatures and freshest product.
- High capacity, factory balanced refrigeration system that has two (2) temperature range options. Standard temperature range maintains cabinet temperatures of 33°F to 41°F (5°C to 5°C), ideally suited for refrigerated bakery and cold deli products. Optional temperature range maintains cabinet temperatures of 42°F to 65°F (5.5°C to 18.3°C), ideally suited for chocolate & wine options.
- Pull Out Condensing unit slides out for easy cleaning and maintenance.

CABINET CONSTRUCTION

- Exterior - powder coated FDA black rounded front and back, black aluminum aesthetic side and front panels. Color options available (upcharge may apply) - white or stainless.
- Curved glass front and side glass panels.

- Interior - powder coated FDA white over CRS material. Color options available (upcharge may apply) - black or stainless.
- Insulation - entire cabinet structure is foamed-in-place using a high density, polyurethane insulation that has zero ozone depletion potential (ODP) and zero global warming potential (GWP).
- Welded, heavy duty steel frame rail, black powder coated for corrosion protection.
- Frame rail fitted with leg levelers.

CURVED FRONT DISPLAY GLASS

- Curved glass front and side panels are single pane tempered glass. Front glass opens from closed to fully open to provide extra large viewing area to maximize product presentation while allowing full frontal access.

REAR DOORS

- Two (2) rear sliding glass doors for back access.
- Each door fitted with 12" (305 mm) long aluminum handle.
- Sliding doors ride on stainless steel V-channel with stainless steel bearings. Doors fit within plastic channel frame.

SHELVING

- Three (3) adjustable heavy duty PVC coated wire shelves standard.
- Each shelf supports a maximum weight of 150 lbs. (69 kg).

PAN CAPACITY

- Cabinet holds six (6) 18"L x 26"D (458 mm x 661 mm) display pans and eight (8) 12"L x 18"D (305 mm x 458 mm) display pans. Pans supplied by others.

LIGHTING

- LED interior lighting, two (2) clips underneath shelf to keep wires in place. Safety shielded.

MODEL FEATURES

- Evaporator is epoxy coated to eliminate the potential of corrosion.
- Front glass swings Up for easy cleaning access.
- Pull out condensing unit slides out for easy cleaning and maintenance.
- Electronic temperature control.
- NSF/ANSI Standard 7 compliant for open food product. Tested and certified for performance at NSF Type II: 80°F (27°C) and 55% relative humidity.

ELECTRICAL

- Unit completely pre-wired at factory and ready for final connection to a 115/60/1 phase, 15 amp dedicated outlet. Cord and plug set included.



OPTIONAL FEATURES/ACCESSORIES

- Upcharge and lead times may apply.
- 230 - 240V / 50 Hz.
 - White exterior
 - Stainless steel exterior
 - Custom exterior colors (contact factory for details)
 - Black interior
 - Custom exterior colors (contact factory for details)
 - Black wire shelves
 - Chrome plated wire shelves
 - Stainless mezzanine shelves

TDM MODEL NUMBER NOMENCLATURE SYSTEM

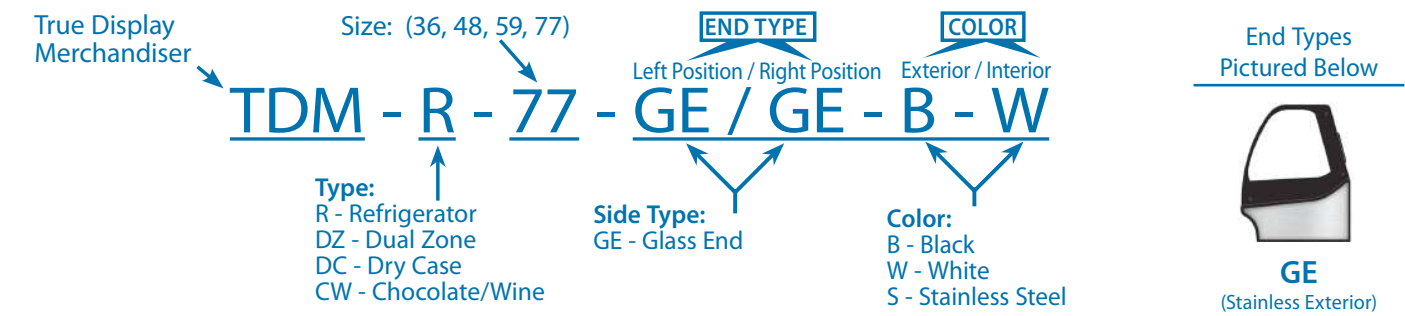

PLAN VIEW

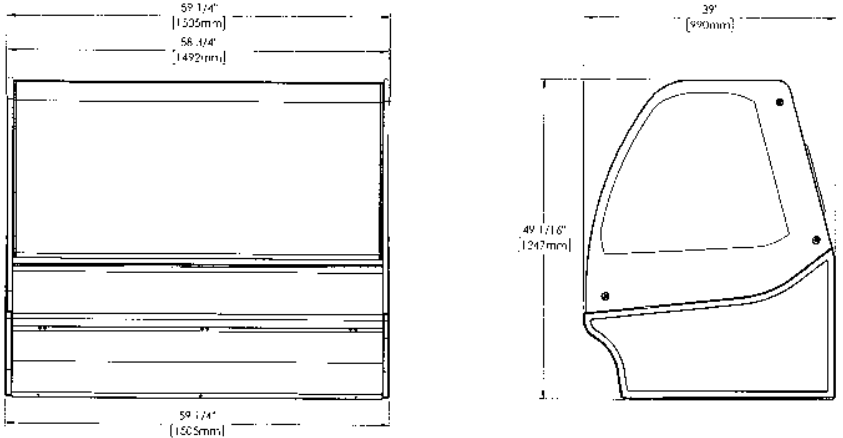

METRIC DIMENSIONS ROUNDED UP TO THE NEAREST WHOLE MILLIMETER
SPECIFICATIONS SUBJECT TO CHANGE WITHOUT NOTICE

	Elevation	Right	Plan	3D	Back

Models TGM-DC-59-SC/SC-B-W TGM-DC-59-SC/SC-W-W TGM-DC-59-SC/SC-S-W TGM-DC-59-SC/SC-S-S

True Glass Merchandiser

Curved Glass, Solid Colored End Refrigerator



TGM-DC-59-SC/SC-B-W



TGM-DC-59-SC/SC-W-W



TGM-DC-59-SC/SC-S-W

Photo
Not Yet
Available

TGM-DC-59-SC/SC-S-S

FEATURES

- ▶ True's "dry" glass merchandisers combines efficient, high volume merchandising with an elegant curved glass front for sophisticated presentation of high end desserts and pastries.
- ▶ Cabinet is NSF/ANSI Standard 2 compliant to hold open food product.
- ▶ Two (2) rear sliding glass doors for back access.
- ▶ Exterior - powder coated FDA black rounded front and back, solid wood sides with aluminum cover and front panels. Color options available (upcharge may apply) - white or stainless.
- ▶ Interior - powder coated FDA white over CRS material. Color options available (upcharge may apply) - black or stainless.
- ▶ Three (3) tiered levels of adjustable wire cantilever shelves that match cabinet interior color. Chrome plated wire shelves standard on stainless units.
- ▶ Curved glass front is single pane tempered glass with extra large viewing area to maximize product presentation.
- ▶ LED interior lighting provides more even lighting throughout the cabinet. Safety shielded.

STANDARD OPTIONS

Exterior Color	Black, White, or Stainless Steel
Interior Color	Black, White, or Stainless Steel
Shelving	White, Black, Chrome, or Mezzanine

ROUGH-IN DATA

Specifications subject to change without notice.
Chart dimensions rounded up to the nearest 1/8" (millimeters rounded up to next whole number).

Model	Rear Doors	Shelves	Cabinet Dimensions (inches) (mm)			Voltage	Amps	NEMA Config.	Cord Length (total ft.) (total m)	Crated Weight White/Black Model (lbs.) (kg)	Crated Weight Stainless Model (lbs.) (kg)
			W	D	H						
TGM-DC-59-SC/SC-Δ-Δ	2	6	59 1/4 1505	39 990	49 1/8 1247	115/60/1	7.0	5-15P	9 2.74	TBD TBD	TBD TBD

Δ Represents Exterior/Interior (B-black, W-White, S-Stainless)

Models:	
TGM-DC-59-SC/SC-B-W	TGM-DC-59-SC/SC-W-W
TGM-DC-59-SC/SC-S-W	TGM-DC-59-SC/SC-S-S

True Glass Merchandiser:

Curved Glass, Solid Colored End Refrigerator



STANDARD FEATURES

DESIGN

- True's dry display case glass merchandiser combines efficient, high volume merchandising and exceptional refrigeration with an elegant curved glass front for sophisticated presentation of high end deli, desserts and pastries.
- Designed to provide an attractive companion to our TGM-R "refrigerated" glass merchandiser. Please note: If units are banked together, because of side panel, a 1/2" (13mm) gap will remain between units.

CABINET CONSTRUCTION

- Exterior - powder coated FDA black rounded front and back, solid wood sides with aluminum cover and front panels. Color options available (upcharge may apply) - white or stainless.
- Curved glass front and side glass panels.
- Interior - powder coated FDA white over CRS material. Color options available (upcharge may apply) - black or stainless.
- Insulation - entire cabinet structure is foamed-in-place using a high density, polyurethane insulation that has zero ozone depletion potential (ODP) and zero global warming potential (GWP).
- Welded, heavy duty steel frame rail, black powder coated for corrosion protection.
- Frame rail fitted with leg levelers.

CURVED FRONT DISPLAY GLASS

- Curved glass front is single pane tempered glass with extra large viewing area to maximize product presentation.

REAR DOORS

- Two (2) rear sliding glass doors for back access.
- Each door fitted with 12" (305 mm) long aluminum handle.
- Sliding doors ride on stainless steel V-channel with stainless steel bearings. Doors fit within plastic channel frame.

SHELVING

- Six (6) adjustable heavy duty PVC coated wire shelves standard.
- Each shelf supports a maximum weight of 150 lbs. (69 kg).

PAN CAPACITY

- Cabinet holds six (6) 18"L x 26"D (458 mm x 661 mm) display pans and eight (8) 12"L x 18"D (305 mm x 458 mm) display pans. Pans supplied by others.

LIGHTING

- LED interior lighting, two (2) clips underneath shelf to keep wires in place. Safety shielded.

MODEL FEATURES

- NSF/ANSI Standard 2 compliant for open food product.

ELECTRICAL

- Unit completely pre-wired at factory and ready for final connection to a 115/60/1 phase, 15 amp dedicated outlet. Cord and plug set included.



STANDARD OPTIONS

Upcharge and lead times may apply.

- Black exterior
- White exterior
- Stainless steel exterior
- White interior
- Black interior
- Stainless steel interior
- Solid Colored Exterior Sides with color matching interior (SC)
- White wire shelves
- Black wire shelves
- Chrome plated wire shelves
- Stainless steel mezzanine shelves

OPTIONAL FEATURES/ACCESSORIES

Upcharge and lead times may apply.

- Custom exterior colors (contact factory for details)
- Glass shelves
- Frosted glass shelves
- Ratchet lock
- Electrical Receptacle
- Exterior top scale shelf
- Exterior small top service shelf
- Exterior medium top service shelf
- Exterior large top service shelf
- External front shelf kit (only available in black)
- External rear service shelf shelf kit (only available in black)
- 4" (102mm) Castors
- 2 1/2" (64mm) castors
- 6" (153mm) legs

TGM MODEL NUMBER NOMENCLATURE SYSTEM

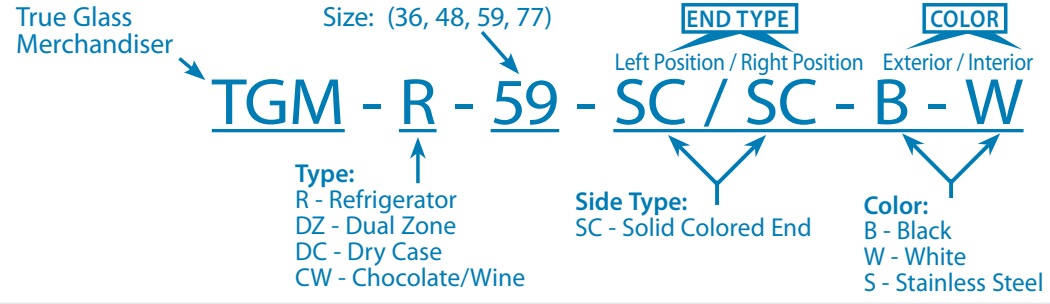

PLAN VIEW

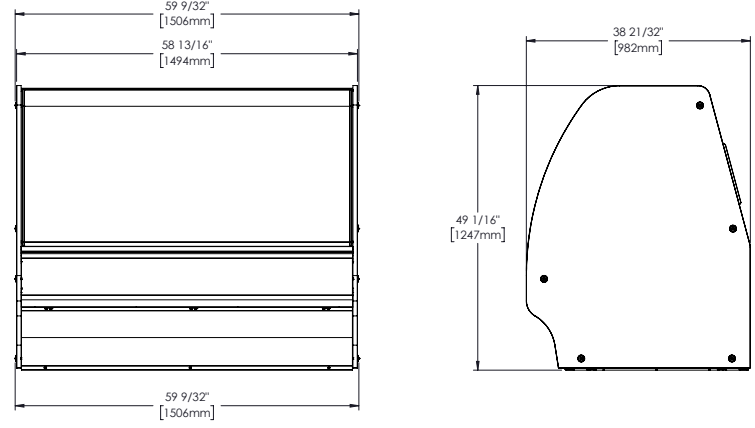

METRIC DIMENSIONS ROUNDED UP TO THE NEAREST WHOLE MILLIMETER
SPECIFICATIONS SUBJECT TO CHANGE WITHOUT NOTICE

	Elevation	Right	Plan	3D	Back

Models TGM-DZ-59-SC/SC-B-W TGM-DZ-59-SC/SC-W-W TGM-DZ-59-SC/SC-S-W TGM-DZ-59-SC/SC-S-S

True Glass Merchandiser

Curved Glass, Solid Colored End Dual Zone



TGM-DZ-59-SC/SC-B-W



TGM-DZ-59-SC/SC-W-W



TGM-DZ-59-SC/SC-S-W



TGM-DZ-59-SC/SC-S-S

FEATURES

- ▶ True's dual zone glass merchandisers combine efficient, high volume merchandising and exceptional refrigeration with an elegant curved glass front for sophisticated presentation of high end desserts and pastries.
- ▶ Factory engineered, self-contained, capillary tube system using environmentally friendly R290 hydrocarbon refrigerant that has zero (0) ozone depletion potential (ODP), & 0.02 global warming potential (GWP).
- ▶ Refrigerated section features high capacity, factory balanced refrigeration system. Standard temperature range maintains cabinet temperatures of 33°F to 41°F (.5°C to 5°C), ideally suited for refrigerated bakery and cold deli products.
- ▶ Two (2) rear sliding glass doors for back access.
- ▶ Exterior - powder coated FDA black rounded front and back, solid wood sides with aluminum cover and front panels. Color options available (upcharge may apply) - white or stainless.
- ▶ Interior - powder coated FDA white over CRS material. Color options available (upcharge may apply) - black or stainless.
- ▶ Three (3) tiered levels of adjustable wire cantilever shelves that match cabinet interior color. Chrome plated wire shelves standard on stainless units.
- ▶ Curved glass front is single pane tempered glass with extra large viewing area to maximize product presentation.
- ▶ LED interior lighting provides more even lighting throughout the cabinet. Safety shielded.

STANDARD OPTIONS

Exterior Color	Black, White, or Stainless Steel
Interior Color	Black, White, or Stainless Steel
Shelving	White, Black, Chrome, or Mezzanine

ROUGH-IN DATA

Specifications subject to change without notice. Chart dimensions rounded up to the nearest 1/8" (millimeters rounded up to next whole number).

Model	Rear Doors	Shelves	Cabinet Dimensions (inches) (mm)			HP	Voltage	Amps	NEMA Config.	Cord Length (total ft.) (total m)	Crated Weight White/Black Model (lbs.) (kg)	Crated Weight Stainless Model (lbs.) (kg)
			W	D	H							
TGM-DZ-59-SC/SC-Δ-Δ	2	6	59 1/4 1505	39 990	49 3/8 1247	1/4	115/60/1	10.0	5-15P	9 2.74	770 350	TBD TBD

Δ Represents Exterior/Interior (B-black, W-White, S-Stainless)

Models:	
TGM-DZ-59-SC/SC-B-W	TGM-DZ-59-SC/SC-W-W
TGM-DZ-59-SC/SC-S-W	TGM-DZ-59-SC/SC-S-S

True Glass Merchandiser:

Curved Glass, Solid Colored End Dual Zone



STANDARD FEATURES

DESIGN

- True's combination "refrigerated" and "dry" display case glass merchandiser combines efficient, high volume merchandising and exceptional refrigeration with an elegant curved glass front for sophisticated presentation of high end end deli, desserts and pastries.
- Please note: If units are banked together, because of side panel, a 1/2" (13mm) gap will remain between units.

REFRIGERATION SYSTEM

- Factory engineered, self-contained, capillary tube system using environmentally friendly R290 hydrocarbon refrigerant that has zero (0) ozone depletion potential (ODP), & 0.02 global warming potential (GWP).
- True's self-cleaning RCU technology eliminates the need to clean the condenser coil, reduces energy consumption and helps maintain the coldest temperatures and freshest product.
- High capacity, factory balanced refrigeration system that has two (2) temperature range options. Standard temperature range maintains cabinet temperatures of 33°F to 41°F (.5°C to 5°C), ideally suited for refrigerated bakery and cold deli products. Optional temperature range maintains cabinet temperatures of 42°F to 65°F (5.5°C to 18.3°C), ideally suited for chocolate & wine options.
- Pull Out Condensing unit slides out for easy cleaning and maintenance.

CABINET CONSTRUCTION

- Exterior - powder coated FDA black rounded front and back, solid wood sides with aluminum cover and front panels. Color options available (upcharge may apply) - white or stainless.
- Curved glass front and side glass panels.
- Interior - powder coated FDA white over CRS material. Color options available (upcharge may apply) - black or stainless.
- Insulation - entire cabinet structure is foamed-in-place using a high density, polyurethane insulation that has zero ozone depletion potential (ODP) and zero global warming potential (GWP).
- Welded, heavy duty steel frame rail, black powder coated for corrosion protection.
- Frame rail fitted with leg levelers.

CURVED FRONT DISPLAY GLASS

- Curved glass front is single pane tempered glass with extra large viewing area to maximize product presentation.

REAR DOORS

- Two (2) rear sliding glass doors for back access.
- Each door fitted with 12" (305 mm) long aluminum handle.
- Sliding doors ride on stainless steel V-channel with stainless steel bearings. Doors fit within plastic channel frame.

SHELVING

- Six (6) adjustable heavy duty PVC coated wire shelves standard.
- Each shelf supports a maximum weight of 150 lbs. (69 kg).

PAN CAPACITY

- Cabinet holds six (6) 18" L x 26" D (458 mm x 661 mm) display pans and eight (8) 12" L x 18" D (305 mm x 458 mm) display pans. Pans supplied by others.

LIGHTING

- LED interior lighting, two (2) clips underneath shelf to keep wires in place. Safety shielded.

MODEL FEATURES

- Evaporator is epoxy coated to eliminate the potential of corrosion.
- Pull out condensing unit slides out for easy cleaning and maintenance.
- Electronic temperature control.
- NSF/ANSI Standard 7 compliant for open food product. Tested and certified for performance at NSF Type II: 80°F (27°C) and 55% relative humidity.

ELECTRICAL

- Unit completely pre-wired at factory and ready for final connection to a 115/60/1 phase, 15 amp dedicated outlet. Cord and plug set included.



STANDARD OPTIONS

Upcharge and lead times may apply.

- Black exterior
- White exterior
- Stainless steel exterior
- White interior
- Black interior
- Stainless steel interior
- Solid Colored Exterior Sides with color matching interior (SC)
- White wire shelves
- Black wire shelves
- Chrome plated wire shelves
- Stainless steel mezzanine shelves

OPTIONAL FEATURES/ACCESSORIES

Upcharge and lead times may apply.

- Custom exterior colors (contact factory for details)
- Chocolate/Wine model available
- Glass shelves
- Frosted glass shelves
- Ratchet lock
- Electrical Receptacle
- Exterior top scale shelf
- Exterior small top service shelf
- Exterior medium top service shelf
- Exterior large top service shelf
- External front shelf kit (only available in black)
- External rear service shelf shelf kit (only available in black)
- 4" (102mm) Castors
- 2 1/2" (64mm) castors
- 6" (153mm) legs

TGM MODEL NUMBER NOMENCLATURE SYSTEM

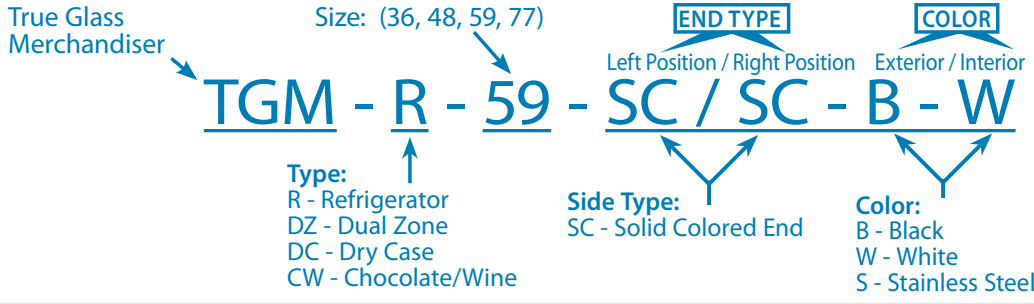

Note: Dual Zone models Not Available in 36 size models.

PLAN VIEW

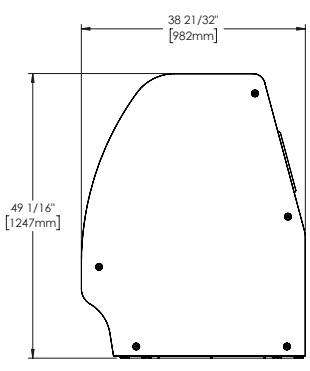
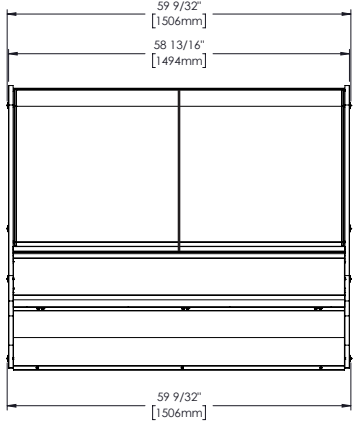

METRIC DIMENSIONS ROUNDED UP TO THE NEAREST WHOLE MILLIMETER
SPECIFICATIONS SUBJECT TO CHANGE WITHOUT NOTICE



Models TGM-R-59-SC/SC-B-W TGM-R-59-SC/SC-W-W TGM-R-59-SC/SC-S-W TGM-R-59-SC/SC-S-S

True Glass Merchandiser

Curved Glass, Solid Colored End Refrigerator



TGM-R-59-SC/SC-B-W



TGM-R-59-SC/SC-W-W



TGM-R-59-SC/SC-S-W



TGM-R-59-SC/SC-S-S

FEATURES

- ▶ True's refrigerated glass merchandisers combine efficient, high volume merchandising and exceptional refrigeration with an elegant curved glass front for sophisticated presentation of high end desserts and pastries.
- ▶ Factory engineered, self-contained, capillary tube system using environmentally friendly R290 hydrocarbon refrigerant that has zero (0) ozone depletion potential (ODP), & 0.02 global warming potential (GWP).
- ▶ High capacity, factory balanced refrigeration system. Standard temperature range maintains cabinet temperatures of 33°F to 41°F (.5°C to 5°C), ideally suited for refrigerated bakery and cold deli products.
- ▶ Cabinet is NSF/ANSI Standard 7 compliant to hold open food product.
- ▶ Two (2) rear sliding glass doors for back access.
- ▶ Exterior - powder coated FDA black rounded front and back, solid wood sides with aluminum cover and front panels. Color options available (upcharge may apply) - white or stainless.
- ▶ Interior - powder coated FDA white over CRS material. Color options available (upcharge may apply) - black or stainless.
- ▶ Three (3) tiered levels of adjustable wire cantilever shelves that match cabinet interior color. Chrome plated wire shelves standard on stainless units.
- ▶ Curved glass front is single pane tempered glass with extra large viewing area to maximize product presentation.
- ▶ LED interior lighting provides more even lighting throughout the cabinet. Safety shielded.

STANDARD OPTIONS

Exterior Color	Black, White, or Stainless Steel
Interior Color	Black, White, or Stainless Steel
Shelving	White, Black, Chrome, or Mezzanine

ROUGH-IN DATA

Specifications subject to change without notice. Chart dimensions rounded up to the nearest 1/8" (millimeters rounded up to next whole number).

Model	Rear Doors	Shelves	Cabinet Dimensions (inches) (mm)			HP	Voltage	Amps	NEMA Config.	Cord Length (total ft.) (total m)	Crated Weight White/Black Model (lbs.) (kg)	Crated Weight Stainless Model (lbs.) (kg)
			W	D	H							
TGM-R-59-SC/SC-Δ-Δ	2	6	59¼ 1505	39 990	49⅞ 1247	½	115/60/1 220-240V/50Hz	12.0 3.0	5-15P ▲	9 2.74	TBD TBD	TBD TBD

Δ Represents Exterior/Interior (B-black, W-White, S-Stainless)

▲ Plug type varies by country.

Models:		True Glass Merchandiser:	
TGM-R-59-SC/SC-B-W	TGM-R-59-SC/SC-W-W	<i>Curved Glass, Solid Colored End Refrigerator</i>	
TGM-R-59-SC/SC-S-W	TGM-R-59-SC/SC-S-S		

STANDARD FEATURES

DESIGN

- True's refrigerated display case glass merchandiser combines efficient, high volume merchandising and exceptional refrigeration with an elegant curved glass front for sophisticated presentation of high end deli, desserts and pastries.
- Designed to provide an attractive companion to our TGM-DC "dry case" display merchandiser. Please note: If units are banked together, because of side panel, a 1/2" (13mm) gap will remain between units.

REFRIGERATION SYSTEM

- Factory engineered, self-contained, capillary tube system using environmentally friendly R290 hydrocarbon refrigerant that has zero (0) ozone depletion potential (ODP), & 0.02 global warming potential (GWP).
- True's self-cleaning RCU technology eliminates the need to clean the condenser coil, reduces energy consumption and helps maintain the coldest temperatures and freshest product.
- High capacity, factory balanced refrigeration system that has two (2) temperature range options. Standard temperature range maintains cabinet temperatures of 33°F to 41°F (.5°C to 5°C), ideally suited for refrigerated bakery and cold deli products. Optional temperature range maintains cabinet temperatures of 42°F to 65°F (5.5°C to 18.3°C), ideally suited for chocolate & wine options.
- Pull Out Condensing unit slides out for easy cleaning and maintenance.

CABINET CONSTRUCTION

- Exterior - powder coated FDA black rounded front and back, solid wood sides with aluminum cover and front panels. Color options available (upcharge may apply) - white or stainless.
- Curved glass front and side glass panels.
- Interior - powder coated FDA white over CRS material. Color options available (upcharge may apply) - black or stainless.
- Insulation - entire cabinet structure is foamed-in-place using a high density, polyurethane insulation that has zero ozone depletion potential (ODP) and zero global warming potential (GWP).
- Welded, heavy duty steel frame rail, black powder coated for corrosion protection.
- Frame rail fitted with leg levelers.

CURVED FRONT DISPLAY GLASS

- Curved glass front is single pane tempered glass with extra large viewing area to maximize product presentation.

REAR DOORS

- Two (2) rear sliding glass doors for back access.
- Each door fitted with 12" (305 mm) long aluminum handle.
- Sliding doors ride on stainless steel V-channel with stainless steel bearings. Doors fit within plastic channel frame.

SHELVING

- Six (6) adjustable heavy duty PVC coated wire shelves standard.
- Each shelf supports a maximum weight of 150 lbs. (69 kg).

PAN CAPACITY

- Cabinet holds six (6) 18"L x 26"D (458 mm x 661 mm) display pans and eight (8) 12"L x 18"D (305 mm x 458 mm) display pans. Pans supplied by others.

LIGHTING

- LED interior lighting, two (2) clips underneath shelf to keep wires in place. Safety shielded.

MODEL FEATURES

- Evaporator is epoxy coated to eliminate the potential of corrosion.
- Pull out condensing unit slides out for easy cleaning and maintenance.
- Electronic temperature control.
- NSF/ANSI Standard 7 compliant for open food product. Tested and certified for performance at NSF Type II: 80°F (27°C) and 55% relative humidity.

ELECTRICAL

- Unit completely pre-wired at factory and ready for final connection to a 115/60/1 phase, 15 amp dedicated outlet. Cord and plug set included.



115/60/1
NEMA-5-15R

STANDARD OPTIONS

Upcharge and lead times may apply.

- Black exterior
- White exterior
- Stainless steel exterior
- White interior
- Black interior
- Stainless steel interior
- Solid Colored Exterior Sides with color matching interior (SC)
- White wire shelves
- Black wire shelves
- Chrome plated wire shelves
- Stainless steel mezzanine shelves

OPTIONAL FEATURES/ACCESSORIES

Upcharge and lead times may apply.

- 220-240V/50Hz
- Custom exterior colors (contact factory for details)
- Chocolate/Wine model available
- Glass shelves
- Frosted glass shelves
- Ratchet lock
- Electrical Receptacle
- Exterior top scale shelf
- Exterior small top service shelf
- Exterior medium top service shelf
- Exterior large top service shelf
- External front shelf kit (only available in black)
- External rear service shelf shelf kit (only available in black)
- 4" (102mm) Castors
- 2 1/2" (64mm) castors
- 6" (153mm) legs

TGM MODEL NUMBER NOMENCLATURE SYSTEM

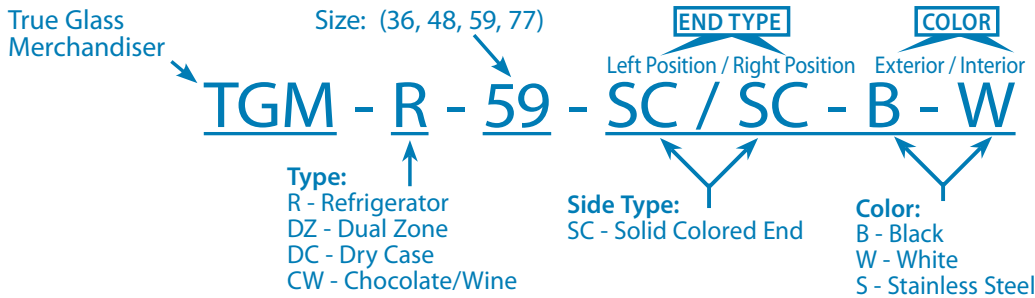

PLAN VIEW

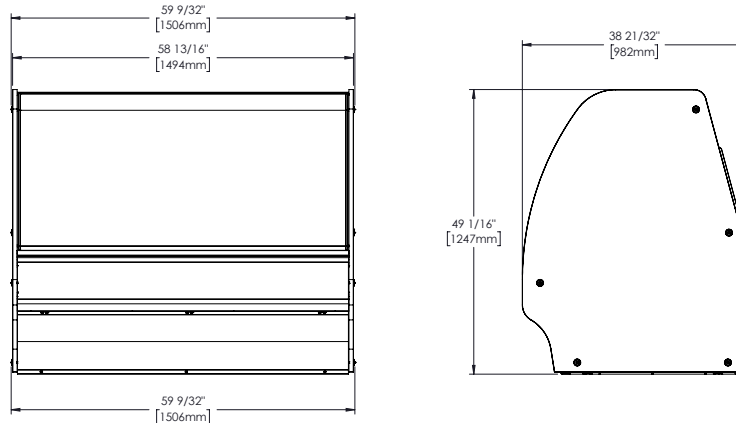

METRIC DIMENSIONS ROUNDED UP TO THE NEAREST WHOLE MILLIMETER

SPECIFICATIONS SUBJECT TO CHANGE WITHOUT NOTICE

	Elevation	Right	Plan	3D	Back

Model:
TCGG-60-HC-LD

Display Case:

Curved Glass Refrigerated Deli Case with Hydrocarbon Refrigerant and LED Lighting



TCGG-60-HC-LD

- ▶ True's curved glass deli case combines efficient, high volume merchandising and exceptional refrigeration with an elegant curved glass front for sophisticated presentation of deli products.
- ▶ High humidity gravity coil refrigeration system maintains 38°F to 40°F (3.3°C to 4.4°C) for the freshest display of meats, cheeses and deli products.
- ▶ Factory engineered, self-contained, capillary tube system using environmentally friendly R290 hydrocarbon refrigerant that has zero (0) ozone depletion potential (ODP), & three (3) global warming potential (GWP).
- ▶ Cabinet is NSF/ANSI Standard 7 certified to hold open food product.
- ▶ Insulated double panel curved front glass provides maximum insulation value for greater efficiency and energy savings. Both panes are tempered for safety.
- ▶ Four (4) adjustable, lighted, cantilevered PVC coated shelves.
- ▶ LED lights are low UV emitting to enhance product appearance and increase shelf life.
- ▶ White laminated vinyl exterior. Stainless steel top and trim.
- ▶ White aluminum interior sides and top. Stainless steel floor with coved corners.

ROUGH-IN DATA

Chart dimensions rounded up to the nearest 1/8" (millimeters rounded up to next whole number). Specifications subject to change without notice.

Model	Doors	Shelves	Cabinet Dimensions (inches) (mm)			HP	Voltage	Amps	NEMA Config.	Cord Length (total ft.) (total m)	Crated Weight (lbs.) (kg)
			W	D†	H						
TCGG-60-HC-LD	2	4	60¼ 1531	35¼ 896	47¾ 1213	½ N/A	115/60/1	5.3 N/A	5-15P	9 2.74	550 250

† Depth does not include 7/8" (23 mm) for door handles.

Model:
TCGG-60-HC-LD

Display Case:
Curved Glass Refrigerated Deli Case with Hydrocarbon Refrigerant and LED Lighting



STANDARD FEATURES

DESIGN

- True's curved glass deli display case combines efficient, high volume merchandising and exceptional refrigeration with an elegant curved glass front for sophisticated presentation of deli products.
- Gravity coil refrigeration system guarantees the freshest display of meats, cheeses and deli products.

REFRIGERATION SYSTEM

- Factory engineered, self-contained, capillary tube system using environmentally friendly R290 hydrocarbon refrigerant that has zero (0) ozone depletion potential (ODP), & three (3) global warming potential (GWP).
- Extra large evaporator coil balanced with higher horsepower compressor and large condenser maintains 38°F to 40°F (3.3°C to 4.4°C).
- High humidity gravity coil refrigeration system. Ideally suited for deli meats, cheeses and salads.
- Condensing unit located behind panel in back of unit. Entire system slides out for easy cleaning and maintenance.
- Automatic defrost system; time-initiated, time-terminated.

CABINET CONSTRUCTION

- Exterior - durable and permanent no peel or chip white powder coated cold rolled steel with stainless steel top and trim.
- Interior - White aluminum sides and top with stainless steel floor.

- Insulation - entire cabinet structure is foamed-in-place using a high density, polyurethane insulation that has zero ozone depletion potential (ODP) and zero global warming potential (GWP).
- Welded, heavy duty steel frame rail, black powder coated for corrosion protection.
- Frame rail fitted with leg levelers.

CURVED FRONT DISPLAY GLASS

- Insulated double pane glass provides maximum insulation value for greater efficiency and energy savings. Both panes are tempered for safety.

REAR DOORS

- "Low-E", double pane thermal glass inserts with mitered plastic channel frames.
- Each door fitted with 12" (305 mm) long molded plastic handle.
- Self-closing doors, efficient counter balanced weight system for smooth, even, positive closure. Sliding doors ride on stainless steel V-channel with stainless steel bearings. Doors fit within plastic channel frame.

SHELVING

- Four (4) adjustable, lighted, white heavy duty PVC coated wire shelves 22 1/2" L x 27 7/8" D (572 mm x 709 mm). Shelving system is cantilevered with adjustable angle to maximize presentation.

LIGHTING

- Cabinet equipped with five LED (5) light sources for maximum product display; four (4) shelf mounted and one (1) cabinet mounted.

MODEL FEATURES

- Evaporator is epoxy coated to eliminate the potential of corrosion.
- Four (4) amp exterior scale receptacle.
- NSF/ANSI Standard 7 compliant for open food product.

ELECTRICAL

- Unit completely pre-wired at factory and ready for final connection to a 115/60/1 phase, 15 amp dedicated outlet. Cord and plug set included.



115/60/1
NEMA-5-15R

RECOMMENDED OPERATING CONDITIONS

- TCGG refrigerated models are designed to operate in an environment where temperature and humidity do not exceed 75°F (24°C) and 55% relative humidity.

OPTIONAL FEATURES/ACCESSORIES

Upcharge and lead times may apply.

- 6" (153 mm) standard legs.
- 6" (153 mm) seismic/flanged legs.
- 2 1/2" (64 mm) diameter castors.
- 4" (102 mm) diameter castors.
- Ratchet locks.
- Additional lighted shelves.
- Non-lighted shelves.

PLAN VIEW

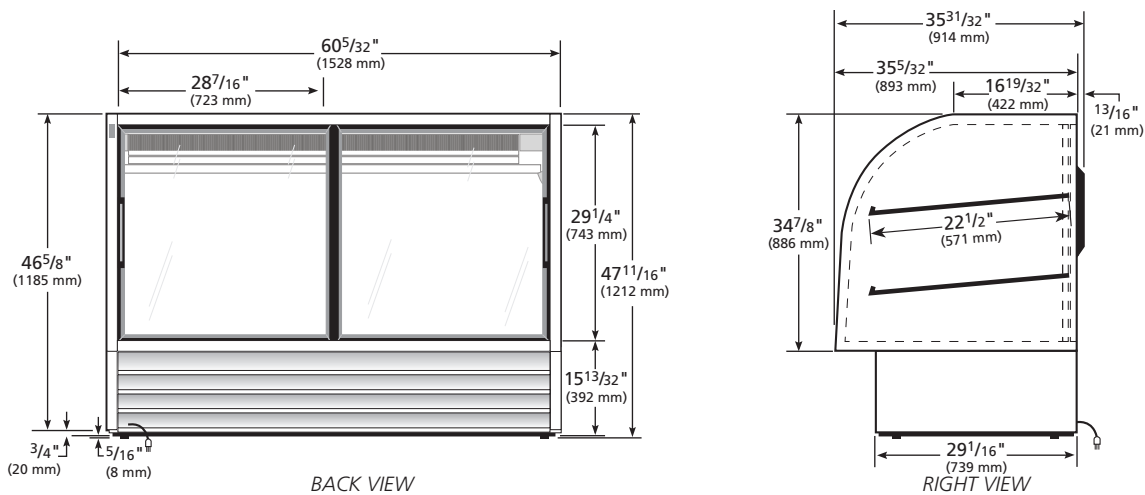

3 YEAR PARTS + LABOR WARRANTY **7 YEAR COMPRESSOR WARRANTY**
(U.S.A. and Canada only)

METRIC DIMENSIONS ROUNDED UP TO THE NEAREST WHOLE MILLIMETER

SPECIFICATIONS SUBJECT TO CHANGE WITHOUT NOTICE



Model	Elevation	Right	Plan	3D	Back
TCGG-60-HC-LD					

Model:
TCGG-60-S-HC-LD

Display Case:

Stainless Steel Curved Glass Refrigerated Deli Case with Hydrocarbon Refrigerant and LED Lighting



TCGG-60-S-HC-LD

- ▶ True's curved glass deli case combines efficient, high volume merchandising and exceptional refrigeration with an elegant curved glass front for sophisticated presentation of deli products.
- ▶ High humidity gravity coil refrigeration system maintains 38°F to 40°F (3.3°C to 4.4°C) for the freshest display of meats, cheeses and deli products.
- ▶ Factory engineered, self-contained, capillary tube system using environmentally friendly R290 hydrocarbon refrigerant that has zero (0) ozone depletion potential (ODP), & three (3) global warming potential (GWP).
- ▶ Cabinet is NSF/ANSI Standard 7 certified to hold open food product.
- ▶ Insulated double pane curved front glass provides maximum insulation value for greater efficiency and energy savings. Both panes are tempered for safety.
- ▶ Four (4) adjustable, lighted, cantilevered PVC coated shelves.
- ▶ LED lights are low UV emitting to enhance product appearance and increase shelf life.
- ▶ All stainless steel interior and exterior.

ROUGH-IN DATA

Chart dimensions rounded up to the nearest 1/8" (millimeters rounded up to next whole number). Specifications subject to change without notice.

Model	Doors	Shelves	Cabinet Dimensions (inches) (mm)			HP	Voltage	Amps	NEMA Config.	Cord Length (total ft.) (total m)	Crated Weight (lbs.) (kg)
			W	D†	H						
TCGG-60-S-HC-LD	2	4	60¼ 1531	35¼ 896	47¾ 1213	½ N/A	115/60/1	5.3 N/A	5-15P	9 2.74	555 252

† Depth does not include 7/8" (23 mm) for door handles.

Model:
TCGG-60-S-HC-LD

Display Case:

*Stainless Steel Curved Glass Refrigerated Deli Case
with Hydrocarbon Refrigerant and LED Lighting*

true®

STANDARD FEATURES

DESIGN

- True's curved glass deli display case combines efficient, high volume merchandising and exceptional refrigeration with an elegant curved glass front for sophisticated presentation of deli products.
- Gravity coil refrigeration system guarantees the freshest display of meats, cheeses and deli products.

REFRIGERATION SYSTEM

- Factory engineered, self-contained, capillary tube system using environmentally friendly R290 hydrocarbon refrigerant that has zero (0) ozone depletion potential (ODP), & three (3) global warming potential (GWP).
- Extra large evaporator coil balanced with higher horsepower compressor and large condenser maintains 38°F to 40°F (3.3°C to 4.4°C).
- High humidity gravity coil refrigeration system. Ideally suited for deli meats, cheeses and salads.
- Condensing unit located behind panel in back of unit. Entire system slides out for easy cleaning and maintenance.
- Automatic defrost system; time-initiated, time-terminated.

CABINET CONSTRUCTION

- Exterior - all stainless steel front, sides, back and top.
- Interior - all stainless steel sides and stainless steel floor with coved corners.

- Insulation - entire cabinet structure is foamed-in-place using a high density, polyurethane insulation that has zero ozone depletion potential (ODP) and zero global warming potential (GWP).
- Welded, heavy duty steel frame rail, black powder coated for corrosion protection.
- Frame rail fitted with leg levelers.

CURVED FRONT DISPLAY GLASS

- Insulated double pane glass provides maximum insulation value for greater efficiency and energy savings. Both panes are tempered for safety.

REAR DOORS

- "Low-E", double pane thermal glass inserts with mitered plastic channel frames.
- Each door fitted with 12" (305 mm) long molded plastic handle.
- Self-closing doors, efficient counter balanced weight system for smooth, even, positive closure. Sliding doors ride on stainless steel V-channel with stainless steel bearings. Doors fit within plastic channel frame.

SHELVING

- Four (4) adjustable, lighted, white heavy duty PVC coated wire shelves 22 1/2" L x 27 7/8" D (572 mm x 709 mm). Shelving system is cantilevered with adjustable angle to maximize presentation.

LIGHTING

- Cabinet equipped with five LED (5) light sources for maximum product display; four (4) shelf mounted and one (1) cabinet mounted.

MODEL FEATURES

- Evaporator is epoxy coated to eliminate the potential of corrosion.
- Four (4) amp exterior scale receptacle.
- NSF/ANSI Standard 7 compliant for open food product.

ELECTRICAL

- Unit completely pre-wired at factory and ready for final connection to a 115/60/1 phase, 20 amp dedicated outlet. Cord and plug set included.



115/60/1
NEMA-5-15R

RECOMMENDED OPERATING CONDITIONS

- TCGG refrigerated models are designed to operate in an environment where temperature and humidity do not exceed 75°F (24°C) and 55% relative humidity.

OPTIONAL FEATURES/ACCESSORIES

Upcharge and lead times may apply.

- 6" (153 mm) standard legs.
- 6" (153 mm) seismic/flanged legs.
- 2 1/2" (64 mm) diameter castors.
- 4" (102 mm) diameter castors.
- Ratchet locks.
- Additional lighted shelves.
- Non-lighted shelves.

PLAN VIEW

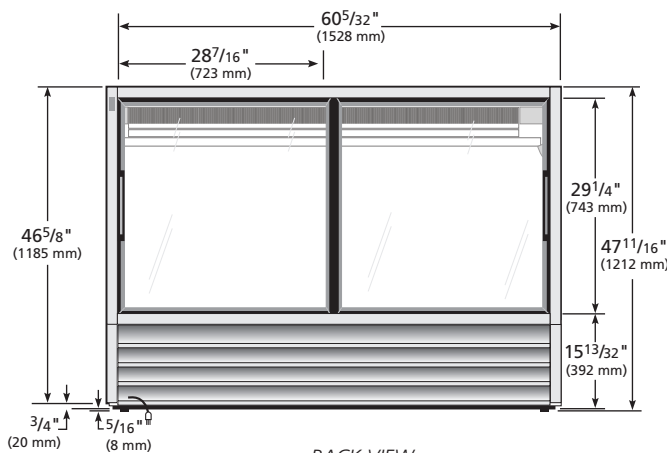

BACK VIEW

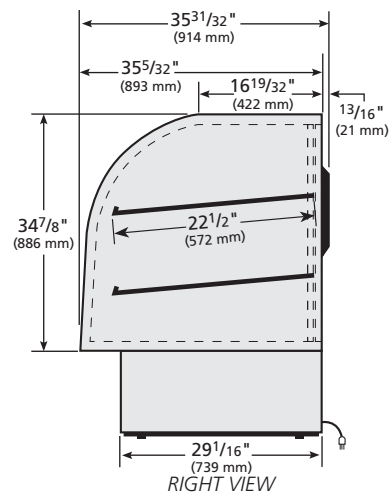

RIGHT VIEW



METRIC DIMENSIONS ROUNDED UP TO THE NEAREST WHOLE MILLIMETER

SPECIFICATIONS SUBJECT TO CHANGE WITHOUT NOTICE



Model	Elevation	Right	Plan	3D	Back
TCGG-60-S-HC-LD					

Model:
TCGG-72-HC-LD

Display Case:

Curved Glass Refrigerated Deli Case with Hydrocarbon Refrigerant and LED Lighting



TCGG-72-HC-LD

- ▶ True's curved glass deli case combines efficient, high volume merchandising and exceptional refrigeration with an elegant curved glass front for sophisticated presentation of deli products.
- ▶ High humidity gravity coil refrigeration system maintains 38°F to 40°F (3.3°C to 4.4°C) for the freshest display of meats, cheeses and deli products.
- ▶ Factory engineered, self-contained, capillary tube system using environmentally friendly R290 hydrocarbon refrigerant that has zero (0) ozone depletion potential (ODP), & three (3) global warming potential (GWP).
- ▶ Cabinet is NSF/ANSI Standard 7 certified to hold open food product.
- ▶ Insulated double pane curved front glass provides maximum insulation value for greater efficiency and energy savings. Both panes are tempered for safety.
- ▶ Two (2) adjustable, lighted, cantilevered PVC coated shelves.
- ▶ LED lights are low UV emitting to enhance product appearance and increase shelf life.
- ▶ Exterior - durable and permanent no peel or chip white powder coated cold rolled steel with stainless steel top and trim.
- ▶ White aluminum interior sides and top. Stainless steel floor with covered corners.

ROUGH-IN DATA

Chart dimensions rounded up to the nearest 1/8" (millimeters rounded up to next whole number). Specifications subject to change without notice.

Model	Doors	Shelves	Cabinet Dimensions (inches) (mm)			HP	Voltage	Amps	NEMA Config.	Cord Length (total ft.) (total m)	Crated Weight (lbs.) (kg)
			W	D†	H						
TCGG-72-HC-LD	2	2	72¼ 1836	35¼ 896	47¾ 1213	½ N/A	115/60/1	5.3 N/A	5-15P	9 2.74	725 329

† Depth does not include 7/8" (23 mm) for door handles.

Model:
TCGG-72-HC-LD

Display Case:
*Curved Glass Refrigerated Deli Case with
Hydrocarbon Refrigerant and LED Lighting*



STANDARD FEATURES

DESIGN

- True's curved glass deli display case combines efficient, high volume merchandising and exceptional refrigeration with an elegant curved glass front for sophisticated presentation of deli products.
- Gravity coil refrigeration system guarantees the freshest display of meats, cheeses and deli products.

REFRIGERATION SYSTEM

- Factory engineered, self-contained, capillary tube system using environmentally friendly R290 hydrocarbon refrigerant that has zero (0) ozone depletion potential (ODP), & three (3) global warming potential (GWP).
- Extra large evaporator coil balanced with higher horsepower compressor and large condenser maintains 38°F to 40°F (3.3°C to 4.4°C).
- High humidity gravity coil refrigeration system. Ideally suited for deli meats, cheeses and salads.
- Condensing unit located behind panel in back of unit. Entire system slides out for easy cleaning and maintenance.
- Automatic defrost system; time-initiated, time-terminated.

CABINET CONSTRUCTION

- Exterior - durable and permanent no peel or chip white powder coated cold rolled steel with stainless steel top and trim.
- Interior - White aluminum sides and top with stainless steel floor.

- Insulation - entire cabinet structure is foamed-in-place using a high density, polyurethane insulation that has zero ozone depletion potential (ODP) and zero global warming potential (GWP).
- Welded, heavy duty steel frame rail, black powder coated for corrosion protection.
- Frame rail fitted with leg levelers.

CURVED FRONT DISPLAY GLASS

- Insulated double pane glass provides maximum insulation value for greater efficiency and energy savings. Both panes are tempered for safety.

REAR DOORS

- "Low-E", double pane thermal glass inserts with mitered plastic channel frames.
- Each door fitted with 12" (305 mm) long molded plastic handle.
- Self-closing doors, efficient counter balanced weight system for smooth, even, positive closure. Sliding doors ride on stainless steel V-channel with stainless steel bearings. Doors fit within plastic channel frame.

SHELVING

- Two (2) adjustable, lighted, white heavy duty PVC coated wire shelves 66⁷/₈" L x 22⁵/₃₂" D (1699 mm x 563 mm). Shelving system is cantilevered with adjustable angle to maximize presentation.

LIGHTING

- Cabinet equipped with three LED (3) light sources for maximum product display; two (2) shelf mounted and one (1) cabinet mounted.

MODEL FEATURES

- Evaporator is epoxy coated to eliminate the potential of corrosion.
- Four (4) amp exterior scale receptacle.
- NSF/ANSI Standard 7 compliant for open food product.

ELECTRICAL

- Unit completely pre-wired at factory and ready for final connection to a 115/60/1 phase, 15 amp dedicated outlet. Cord and plug set included.



115/60/1
NEMA-5-15R

RECOMMENDED OPERATING CONDITIONS

- TCGG refrigerated models are designed to operate in an environment where temperature and humidity do not exceed 75°F (24°C) and 55% relative humidity.

OPTIONAL FEATURES/ACCESSORIES

Upcharge and lead times may apply.

- 6" (153 mm) standard legs.
- 6" (153 mm) seismic/flanged legs.
- 2 1/2" (64 mm) diameter castors.
- 4" (102 mm) diameter castors.
- Ratchet locks.
- Additional lighted shelves.
- Non-lighted shelves.

PLAN VIEW

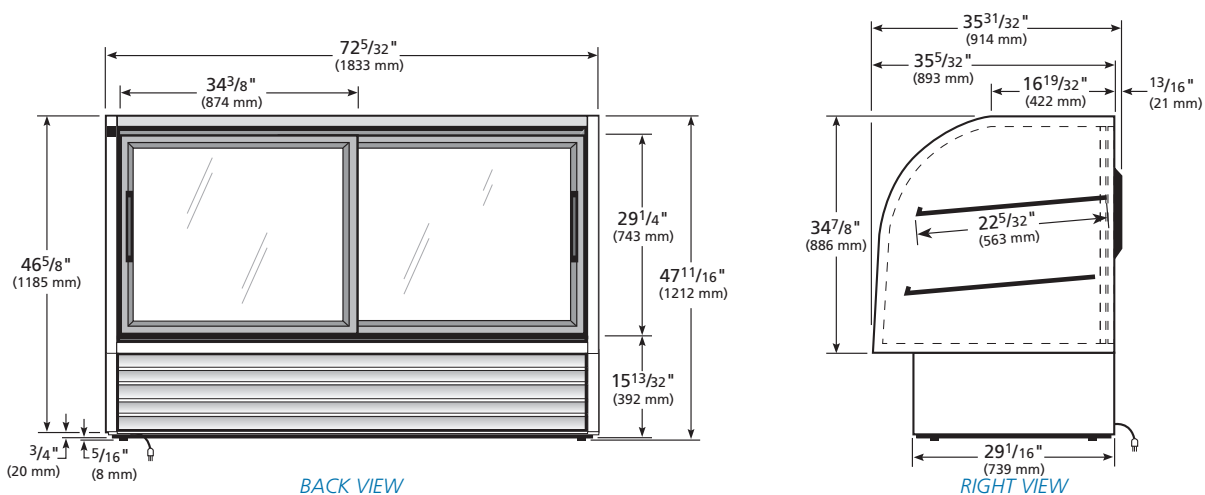

3 YEAR PARTS + LABOR
7 YEAR COMPRESSOR
WARRANTY
 (U.S.A. and Canada only)

METRIC DIMENSIONS ROUNDED UP TO THE NEAREST WHOLE MILLIMETER

SPECIFICATIONS SUBJECT TO CHANGE WITHOUT NOTICE



Model	Elevation	Right	Plan	3D	Back
TCGG-72-HC-LD					

Model:
TCGG-72-S-HC-LD

Display Case:

Stainless Steel Curved Glass Refrigerated Deli Case Hydrocarbon Refrigerant and LED Lighting



TCGG-72-S-HC-LD

- ▶ True's curved glass deli case combines efficient, high volume merchandising and exceptional refrigeration with an elegant curved glass front for sophisticated presentation of deli products.
- ▶ High humidity gravity coil refrigeration system maintains 38°F to 40°F (3.3°C to 4.4°C) for the freshest display of meats, cheeses and deli products.
- ▶ Factory engineered, self-contained, capillary tube system using environmentally friendly R290 hydrocarbon refrigerant that has zero (0) ozone depletion potential (ODP), & three (3) global warming potential (GWP).
- ▶ Cabinet is NSF/ANSI Standard 7 certified to hold open food product.
- ▶ Insulated double pane curved front glass provides maximum insulation value for greater efficiency and energy savings. Both panes are tempered for safety.
- ▶ Two (2) adjustable, lighted, cantilevered PVC coated shelves.
- ▶ LED lights are low UV emitting to enhance product appearance and increase shelf life.
- ▶ All stainless steel interior and exterior.

ROUGH-IN DATA

Chart dimensions rounded up to the nearest 1/8" (millimeters rounded up to next whole number). Specifications subject to change without notice.

Model	Doors	Shelves	Cabinet Dimensions (inches) (mm)			HP	Voltage	Amps	NEMA Config.	Cord Length (total ft.) (total m)	Crated Weight (lbs.) (kg)
			W	D†	H						
TCGG-72-S-HC-LD	2	2	72¼ 1836	35¼ 896	47¾ 1213	½ N/A	115/60/1	5.3 N/A	5-15P	9 2.74	730 331

† Depth does not include 7/8" (23 mm) for door handles.

Model:
TCGG-72-S-HC-LD

Display Case:
Stainless Steel Curved Glass Refrigerated Deli Case Hydrocarbon Refrigerant and LED Lighting



STANDARD FEATURES

DESIGN

- True's curved glass deli display case combines efficient, high volume merchandising and exceptional refrigeration with an elegant curved glass front for sophisticated presentation of deli products.
- Gravity coil refrigeration system guarantees the freshest display of meats, cheeses and deli products.

REFRIGERATION SYSTEM

- Factory engineered, self-contained, capillary tube system using environmentally friendly R290 hydrocarbon refrigerant that has zero (0) ozone depletion potential (ODP), & three (3) global warming potential (GWP).
- Extra large evaporator coil balanced with higher horsepower compressor and large condenser maintains 38°F to 40°F (3.3°C to 4.4°C).
- High humidity gravity coil refrigeration system. Ideally suited for deli meats, cheeses and salads.
- Condensing unit located behind panel in back of unit. Entire system slides out for easy cleaning and maintenance.
- Automatic defrost system; time-initiated, time-terminated.

CABINET CONSTRUCTION

- Exterior - all stainless steel front, sides, back and top.
- Interior - all stainless steel sides and stainless steel floor with coved corners.

- Insulation - entire cabinet structure is foamed-in-place using a high density, polyurethane insulation that has zero ozone depletion potential (ODP) and zero global warming potential (GWP).
- Welded, heavy duty steel frame rail, black powder coated for corrosion protection.
- Frame rail fitted with leg levelers.

CURVED FRONT DISPLAY GLASS

- Insulated double pane glass provides maximum insulation value for greater efficiency and energy savings. Both panes are tempered for safety.

REAR DOORS

- "Low-E", double pane thermal glass inserts with mitered plastic channel frames.
- Each door fitted with 12" (305 mm) long molded plastic handle.
- Self-closing doors, efficient counter balanced weight system for smooth, even, positive closure. Sliding doors ride on stainless steel V-channel with stainless steel bearings. Doors fit within plastic channel frame.

SHELVING

- Two (2) adjustable, lighted, white heavy duty PVC coated wire shelves 66 7/8" L x 22 5/32" D (1699 mm x 563 mm). Shelving system is cantilevered with adjustable angle to maximize presentation.

LIGHTING

- Cabinet equipped with three LED (3) light sources for maximum product display; two (2) shelf mounted and one (1) cabinet mounted.

MODEL FEATURES

- Evaporator is epoxy coated to eliminate the potential of corrosion.
- Four (4) amp exterior scale receptacle.
- NSF/ANSI Standard 7 compliant for open food product.

ELECTRICAL

- Unit completely pre-wired at factory and ready for final connection to a 115/60/1 phase, 15 amp dedicated outlet. Cord and plug set included.



115/60/1
NEMA-5-15R

RECOMMENDED OPERATING CONDITIONS

- TCGG refrigerated models are designed to operate in an environment where temperature and humidity do not exceed 75°F (24°C) and 55% relative humidity.

OPTIONAL FEATURES/ACCESSORIES

Upcharge and lead times may apply.

- 6" (153 mm) standard legs.
- 6" (153 mm) seismic/flanged legs.
- 2 1/2" (64 mm) diameter castors.
- 4" (102 mm) diameter castors.
- Ratchet locks.
- Additional lighted shelves.
- Non-lighted shelves.

PLAN VIEW

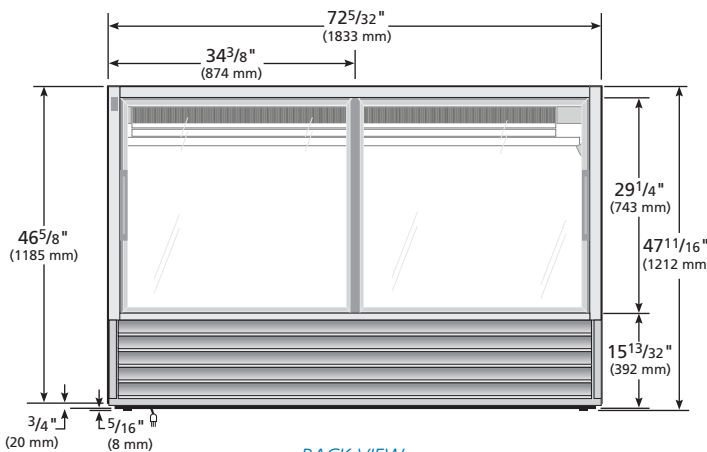

BACK VIEW

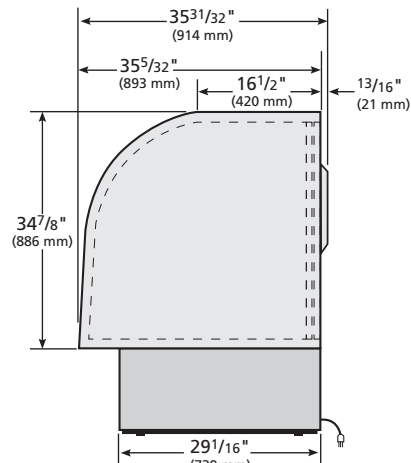

RIGHT VIEW

3 YEAR PARTS + LABOR
7 YEAR COMPRESSOR
WARRANTY
(U.S.A. and Canada only)

METRIC DIMENSIONS ROUNDED UP TO THE NEAREST WHOLE MILLIMETER

SPECIFICATIONS SUBJECT TO CHANGE WITHOUT NOTICE



Model	Elevation	Right	Plan	3D	Back
TCGG-72-S-HC-LD					

Models TGM-DC-77-SC/SC-B-W TGM-DC-77-SC/SC-W-W TGM-DC-77-SC/SC-S-W TGM-DC-77-SC/SC-S-S

True Glass Merchandiser

Curved Glass, Solid Colored End Refrigerator



TGM-DC-77-SC/SC-B-W



TGM-DC-77-SC/SC-W-W



TGM-DC-77-SC/SC-S-W



TGM-DC-77-SC/SC-S-S

FEATURES

- ▶ True's "dry" glass merchandisers combines efficient, high volume merchandising with an elegant curved glass front for sophisticated presentation of high end desserts and pastries.
- ▶ Cabinet is NSF/ANSI Standard 2 compliant to hold open food product.
- ▶ Two (2) rear sliding glass doors for back access.
- ▶ Exterior - powder coated FDA black rounded front and back, solid wood sides with aluminum cover and front panels. Color options available (upcharge may apply) - white or stainless.
- ▶ Interior - powder coated FDA white over CRS material. Color options available (upcharge may apply) - black or stainless.
- ▶ Three (3) tiered levels of adjustable wire cantilever shelves that match cabinet interior color. Chrome plated wire shelves standard on stainless units.
- ▶ Curved glass front is single pane tempered glass with extra large viewing area to maximize product presentation.
- ▶ LED interior lighting provides more even lighting throughout the cabinet. Safety shielded.

STANDARD OPTIONS

Exterior Color	Black, White, or Stainless Steel
Interior Color	Black, White, or Stainless Steel
Shelving	White, Black, Chrome, or Mezzanine

ROUGH-IN DATA

Specifications subject to change without notice. Chart dimensions rounded up to the nearest 1/8" (millimeters rounded up to next whole number).

Model	Rear Doors	Shelves	Cabinet Dimensions (inches) (mm)			Voltage	Amps	NEMA Config.	Cord Length (total ft.) (total m)	Crated Weight White/Black Model (lbs.) (kg)	Crated Weight Stainless Model (lbs.) (kg)
			W	D	H						
TGM-DC-77-SC/SC-Δ-Δ	2	6	77 1/4 1962	39 990	49 3/8 1247	115/60/1	7.0	5-15P	9 2.74	TBD TBD	TBD TBD

Δ Represents Exterior/Interior (B-black, W-White, S-Stainless)

Models:	
TGM-DC-77-SC/SC-B-W	TGM-DC-77-SC/SC-W-W
TGM-DC-77-SC/SC-S-W	TGM-DC-77-SC/SC-S-S

True Glass Merchandiser:

Curved Glass, Solid Colored End Refrigerator



STANDARD FEATURES

DESIGN

- True's dry display case glass merchandiser combines efficient, high volume merchandising and exceptional refrigeration with an elegant curved glass front for sophisticated presentation of high end deli, desserts and pastries.
- Designed to provide an attractive companion to our TGM-R "refrigerated" glass merchandiser. Please note: If units are banked together, because of side panel, a 1/2" (13mm) gap will remain between units.

CABINET CONSTRUCTION

- Exterior - powder coated FDA black rounded front and back, solid wood sides with aluminum cover and front panels. Color options available (upcharge may apply) - white or stainless.
- Curved glass front and side glass panels.
- Interior - powder coated FDA white over CRS material. Color options available (upcharge may apply) - black or stainless.
- Insulation - entire cabinet structure is foamed-in-place using a high density, polyurethane insulation that has zero ozone depletion potential (ODP) and zero global warming potential (GWP).
- Welded, heavy duty steel frame rail, black powder coated for corrosion protection.
- Frame rail fitted with leg levelers.

CURVED FRONT DISPLAY GLASS

- Curved glass front is single pane tempered glass with extra large viewing area to maximize product presentation.

REAR DOORS

- Two (2) rear sliding glass doors for back access.
- Each door fitted with 12" (305 mm) long aluminum handle.
- Sliding doors ride on stainless steel V-channel with stainless steel bearings. Doors fit within plastic channel frame.

SHELVING

- Six (6) adjustable heavy duty PVC coated wire shelves standard.
- Each shelf supports a maximum weight of 150 lbs. (69 kg).

PAN CAPACITY

- Cabinet holds eight (8) 18"L x 26"D (458 mm x 661 mm) display pans and twelve (12) 12"L x 18"D (305 mm x 458 mm) display pans. Pans supplied by others.

LIGHTING

- LED interior lighting, two (2) clips underneath shelf to keep wires in place. Safety shielded.

MODEL FEATURES

- NSF/ANSI Standard 2 compliant for open food product.

ELECTRICAL

- Unit completely pre-wired at factory and ready for final connection to a 115/60/1 phase, 15 amp dedicated outlet. Cord and plug set included.



115/60/1
NEMA-5-15R

STANDARD OPTIONS

Upcharge and lead times may apply.

- Black exterior
- White exterior
- Stainless steel exterior
- White interior
- Black interior
- Stainless steel interior
- Solid Colored Exterior Sides with color matching interior (SC)
- White wire shelves
- Black wire shelves
- Chrome plated wire shelves
- Stainless steel mezzanine shelves

OPTIONAL FEATURES/ACCESSORIES

Upcharge and lead times may apply.

- Custom exterior colors (contact factory for details)
- Glass shelves
- Frosted glass shelves
- Ratchet lock
- Electrical Receptacle
- Exterior top scale shelf
- Exterior small top service shelf
- Exterior medium top service shelf
- Exterior large top service shelf
- External front shelf kit (only available in black)
- External rear service shelf shelf kit (only available in black)

TGM MODEL NUMBER NOMENCLATURE SYSTEM

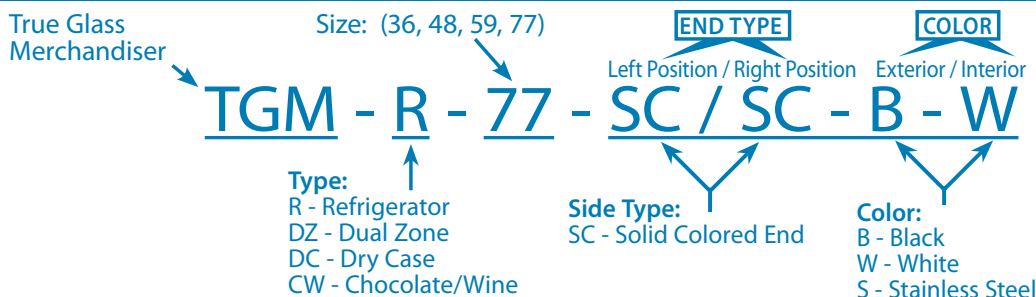

PLAN VIEW

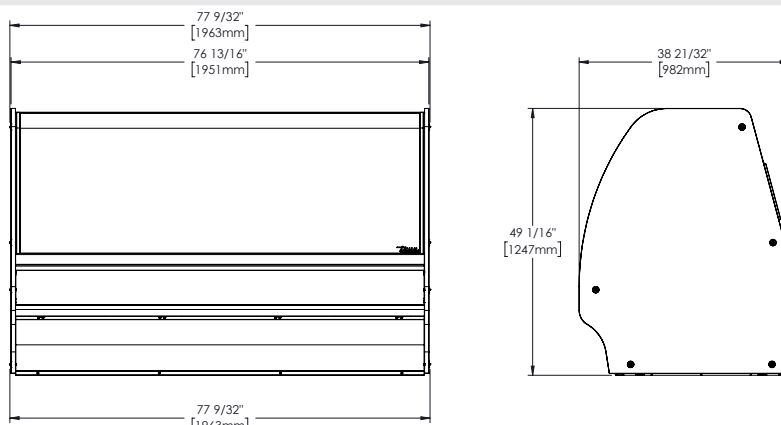

METRIC DIMENSIONS ROUNDED UP TO THE NEAREST WHOLE MILLIMETER
SPECIFICATIONS SUBJECT TO CHANGE WITHOUT NOTICE

	Elevation	Right	Plan	3D	Back

Models **TGM-DZ-77-SC/SC-B-W** **TGM-DZ-77-SC/SC-W-W** **TGM-DZ-77-SC/SC-S-W** **TGM-DZ-77-SC/SC-S-S**
True Glass Merchandiser **Curved Glass, Solid Colored End Dual Zone**



TGM-DZ-77-SC/SC-B-W



TGM-DZ-77-SC/SC-W-W



TGM-DZ-77-SC/SC-S-W



TGM-DZ-77-SC/SC-S-S

FEATURES

- ▶ True's dual zone glass merchandisers combine efficient, high volume merchandising and exceptional refrigeration with an elegant curved glass front for sophisticated presentation of high end desserts and pastries.
- ▶ Factory engineered, self-contained, capillary tube system using environmentally friendly R290 hydrocarbon refrigerant that has zero (0) ozone depletion potential (ODP), & 0.02 global warming potential (GWP).
- ▶ Refrigerated section features high capacity, factory balanced refrigeration system. Standard temperature range maintains cabinet temperatures of 33°F to 41°F (.5°C to 5°C), ideally suited for refrigerated bakery and cold deli products.
- ▶ Two (2) rear sliding glass doors for back access.
- ▶ Exterior - powder coated FDA black rounded front and back, solid wood sides with aluminum cover and front panels. Color options available (upcharge may apply) - white or stainless.
- ▶ Interior - powder coated FDA white over CRS material. Color options available (upcharge may apply) - black or stainless.
- ▶ Three (3) tiered levels of adjustable wire cantilever shelves that match cabinet interior color. Chrome plated wire shelves standard on stainless units.
- ▶ Curved glass front is single pane tempered glass with extra large viewing area to maximize product presentation.
- ▶ LED interior lighting provides more even lighting throughout the cabinet. Safety shielded.

STANDARD OPTIONS

Exterior Color	Black, White, or Stainless Steel
Interior Color	Black, White, or Stainless Steel
Shelving	White, Black, Chrome, or Mezzanine

ROUGH-IN DATA

Specifications subject to change without notice. Chart dimensions rounded up to the nearest 1/8" (millimeters rounded up to next whole number).

Model	Rear Doors	Shelves	Cabinet Dimensions (inches) (mm)				HP	Voltage	Amps	NEMA Config.	Cord Length (total ft.) (total m)	Crated Weight White/Black Model (lbs.) (kg)	Crated Weight Stainless Model (lbs.) (kg)
			W	D	H	HP							
TGM-DZ-77-SC/SC-Δ-Δ	2	6	77¼ 1962	39 990	49⅞ 1247	¼	115/60/1	10.0	5-15P	9 2.74	940 427	TBD TBD	

Δ Represents Exterior/Interior (B-black, W-White, S-Stainless)

Models:	
TGM-DZ-77-SC/SC-B-W	TGM-DZ-77-SC/SC-W-W
TGM-DZ-77-SC/SC-S-W	TGM-DZ-77-SC/SC-S-S

True Glass Merchandiser:

Curved Glass, Solid Colored End Dual Zone



STANDARD FEATURES

DESIGN

- True's combination "refrigerated" and "dry" display case glass merchandiser combines efficient, high volume merchandising and exceptional refrigeration with an elegant curved glass front for sophisticated presentation of high end deli, desserts and pastries.
- Please note: If units are banked together, because of side panel, a 1/2" (13mm) gap will remain between units.

REFRIGERATION SYSTEM

- Factory engineered, self-contained, capillary tube system using environmentally friendly R290 hydrocarbon refrigerant that has zero (0) ozone depletion potential (ODP), & 0.02 global warming potential (GWP).
- True's self-cleaning RCU technology eliminates the need to clean the condenser coil, reduces energy consumption and helps maintain the coldest temperatures and freshest product.
- High capacity, factory balanced refrigeration system that has two (2) temperature range options. Standard temperature range maintains cabinet temperatures of 33°F to 41°F (.5°C to 5°C), ideally suited for refrigerated bakery and cold deli products. Optional temperature range maintains cabinet temperatures of 42°F to 65°F (5.5°C to 18.3°C), ideally suited for chocolate & wine options.
- Pull Out Condensing unit slides out for easy cleaning and maintenance.

CABINET CONSTRUCTION

- Exterior - powder coated FDA black rounded front and back, solid wood sides with aluminum cover and front panels. Color options available (upcharge may apply) - white or stainless.
- Curved glass front and side glass panels.
- Interior - powder coated FDA white over CRS material. Color options available (upcharge may apply) - black or stainless.

- Insulation - entire cabinet structure is foamed-in-place using a high density, polyurethane insulation that has zero ozone depletion potential (ODP) and zero global warming potential (GWP).
- Welded, heavy duty steel frame rail, black powder coated for corrosion protection.
- Frame rail fitted with leg levelers.

CURVED FRONT DISPLAY GLASS

- Curved glass front is single pane tempered glass with extra large viewing area to maximize product presentation.

REAR DOORS

- Two (2) rear sliding glass doors for back access.
- Each door fitted with 12" (305 mm) long aluminum handle.
- Sliding doors ride on stainless steel V-channel with stainless steel bearings. Doors fit within plastic channel frame.

SHELVING

- Six (6) adjustable heavy duty PVC coated wire shelves standard.
- Each shelf supports a maximum weight of 150 lbs. (69 kg).

PAN CAPACITY

- Cabinet holds eight (8) 18"L x 26"D (458 mm x 661 mm) display pans and twelve (12) 12"L x 18"D (305 mm x 458 mm) display pans. Pans supplied by others.

LIGHTING

- LED interior lighting, two (2) clips underneath shelf to keep wires in place. Safety shielded.

MODEL FEATURES

- Evaporator is epoxy coated to eliminate the potential of corrosion.
- Pull out condensing unit slides out for easy cleaning and maintenance.
- Electronic temperature control.
- NSF/ANSI Standard 7 compliant for open food product. Tested and certified for performance at NSF Type II: 80°F (27°C) and 55% relative humidity.

ELECTRICAL

- Unit completely pre-wired at factory and ready for final connection to a 115/60/1 phase, 15 amp dedicated outlet. Cord and plug set included.



115/60/1
NEMA-5-15R

STANDARD OPTIONS

Upcharge and lead times may apply.

- Black exterior
- White exterior
- Stainless steel exterior
- White interior
- Black interior
- Stainless steel interior
- Solid Colored Exterior Sides with color matching interior (SC)
- White wire shelves
- Black wire shelves
- Chrome plated wire shelves
- Stainless steel mezzanine shelves

OPTIONAL FEATURES/ACCESSORIES

Upcharge and lead times may apply.

- Custom exterior colors (contact factory for details)
- Chocolate/Wine model available
- Glass shelves
- Frosted glass shelves
- Ratchet lock
- Electrical Receptacle
- Exterior top scale shelf
- Exterior small top service shelf
- Exterior medium top service shelf
- Exterior large top service shelf
- External front shelf kit (only available in black)
- External rear service shelf kit (only available in black)

TGM MODEL NUMBER NOMENCLATURE SYSTEM

True Glass Merchandiser

Size: (36, 48, 59, 77)

END TYPE

COLOR

Left Position / Right Position

Exterior / Interior

Note: Dual Zone models Not Available in 36 size models.

TGM - R - 77 - SC / SC - B - W

Type:
R - Refrigerator
DZ - Dual Zone
DC - Dry Case
CW - Chocolate/Wine

Side Type:
SC - Solid Colored End

Color:
B - Black
W - White
S - Stainless Steel

PLAN VIEW

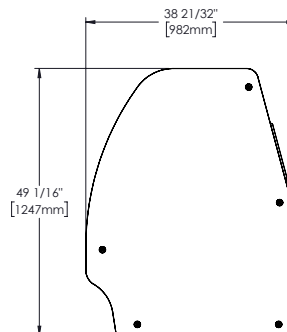
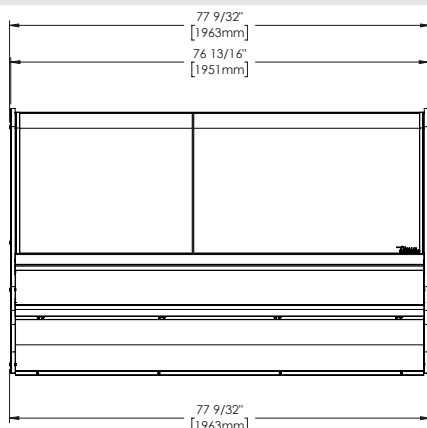

METRIC DIMENSIONS ROUNDED UP TO THE NEAREST WHOLE MILLIMETER
SPECIFICATIONS SUBJECT TO CHANGE WITHOUT NOTICE

	Elevation	Right	Plan	3D	Back

Models TGM-R-77-SC/SC-B-W TGM-R-77-SC/SC-W-W TGM-R-77-SC/SC-S-W TGM-R-77-SC/SC-S-S

True Glass Merchandiser

Curved Glass, Solid Colored End Refrigerator



TGM-R-77-SC/SC-B-W



TGM-R-77-SC/SC-W-W



TGM-R-77-SC/SC-S-W



TGM-R-77-SC/SC-S-S

FEATURES

- ▶ True's refrigerated glass merchandisers combine efficient, high volume merchandising and exceptional refrigeration with an elegant curved glass front for sophisticated presentation of high end desserts and pastries.
- ▶ Factory engineered, self-contained, capillary tube system using environmentally friendly R290 hydrocarbon refrigerant that has zero (0) ozone depletion potential (ODP), & 0.02 global warming potential (GWP).
- ▶ High capacity, factory balanced refrigeration system. Standard temperature range maintains cabinet temperatures of 33°F to 41°F (.5°C to 5°C), ideally suited for refrigerated bakery and cold deli products.
- ▶ Cabinet is NSF/ANSI Standard 7 compliant to hold open food product.
- ▶ Two (2) rear sliding glass doors for back access.
- ▶ Exterior - powder coated FDA black rounded front and back, solid wood sides with aluminum cover and front panels. Color options available (upcharge may apply) - white or stainless.
- ▶ Interior - powder coated FDA white over CRS material. Color options available (upcharge may apply) - black or stainless.
- ▶ Three (3) tiered levels of adjustable wire cantilever shelves that match cabinet interior color. Chrome plated wire shelves standard on stainless units.
- ▶ Curved glass front is single pane tempered glass with extra large viewing area to maximize product presentation.
- ▶ LED interior lighting provides more even lighting throughout the cabinet. Safety shielded.

STANDARD OPTIONS

Exterior Color	Black, White, or Stainless Steel
Interior Color	Black, White, or Stainless Steel
Shelving	White, Black, Chrome, or Mezzanine

ROUGH-IN DATA

Specifications subject to change without notice. Chart dimensions rounded up to the nearest 1/8" (millimeters rounded up to next whole number).

Model	Rear Doors	Shelves	Cabinet Dimensions (inches) (mm)			HP	Voltage	Amps	NEMA Config.	Cord Length (total ft.) (total m)	Crated Weight White/Black Model (lbs.) (kg)	Crated Weight Stainless Model (lbs.) (kg)
			W	D	H							
TGM-R-77-SC/SC-Δ-Δ	2	6	77¼ 1962	39 990	49⅞ 1247	½	115/60/1	12.0	5-15P	9 2.74	855 388	TBD TBD

Δ Represents Exterior/Interior (B-black, W-White, S-Stainless)

Models:		True Glass Merchandiser:	
TGM-R-77-SC/SC-B-W	TGM-R-77-SC/SC-W-W	<i>Curved Glass, Solid Colored End Refrigerator</i>	
TGM-R-77-SC/SC-S-W	TGM-R-77-SC/SC-S-S		

STANDARD FEATURES

DESIGN

- True's refrigerated display case glass merchandiser combines efficient, high volume merchandising and exceptional refrigeration with an elegant curved glass front for sophisticated presentation of high end deli, desserts and pastries.
- Designed to provide an attractive companion to our TGM-DC "dry case" display merchandiser. Please note: If units are banked together, because of side panel, a 1/2" (13mm) gap will remain between units.

REFRIGERATION SYSTEM

- Factory engineered, self-contained, capillary tube system using environmentally friendly R290 hydrocarbon refrigerant that has zero (0) ozone depletion potential (ODP), & 0.02 global warming potential (GWP).
- True's self-cleaning RCU technology eliminates the need to clean the condenser coil, reduces energy consumption and helps maintain the coldest temperatures and freshest product.
- High capacity, factory balanced refrigeration system that has two (2) temperature range options. Standard temperature range maintains cabinet temperatures of 33°F to 41°F (5°C to 5°C), ideally suited for refrigerated bakery and cold deli products. Optional temperature range maintains cabinet temperatures of 42°F to 65°F (5.5°C to 18.3°C), ideally suited for chocolate & wine options.
- Pull Out Condensing unit slides out for easy cleaning and maintenance.

CABINET CONSTRUCTION

- Exterior - powder coated FDA black rounded front and back, solid wood sides with aluminum cover and front panels. Color options available (upcharge may apply) - white or stainless.
- Curved glass front and side glass panels.
- Interior - powder coated FDA white over CRS material. Color options available (upcharge may apply) - black or stainless.

- Insulation - entire cabinet structure is foamed-in-place using a high density, polyurethane insulation that has zero ozone depletion potential (ODP) and zero global warming potential (GWP).
- Welded, heavy duty steel frame rail, black powder coated for corrosion protection.
- Frame rail fitted with leg levelers.

CURVED FRONT DISPLAY GLASS

- Curved glass front is single pane tempered glass with extra large viewing area to maximize product presentation.

REAR DOORS

- Two (2) rear sliding glass doors for back access.
- Each door fitted with 12" (305 mm) long aluminum handle.
- Sliding doors ride on stainless steel V-channel with stainless steel bearings. Doors fit within plastic channel frame.

SHELVING

- Six (6) adjustable heavy duty PVC coated wire shelves standard.
- Each shelf supports a maximum weight of 150 lbs. (69 kg).

PAN CAPACITY

- Cabinet holds eight (8) 18"L x 26"D (458 mm x 661 mm) display pans and twelve (12) 12"L x 18"D (305 mm x 458 mm) display pans. Pans supplied by others.

LIGHTING

- LED interior lighting, two (2) clips underneath shelf to keep wires in place. Safety shielded.

MODEL FEATURES

- Evaporator is epoxy coated to eliminate the potential of corrosion.
- Pull out condensing unit slides out for easy cleaning and maintenance.
- Electronic temperature control.
- NSF/ANSI Standard 7 compliant for open food product. Tested and certified for performance at NSF Type II: 80°F (27°C) and 55% relative humidity.

ELECTRICAL

- Unit completely pre-wired at factory and ready for final connection to a 115/60/1 phase, 15 amp dedicated outlet. Cord and plug set included.



115/60/1
NEMA-5-15R

STANDARD OPTIONS

Upcharge and lead times may apply.

- Black exterior
- White exterior
- Stainless steel exterior
- White interior
- Black interior
- Stainless steel interior
- Solid Colored Exterior Sides with color matching interior (SC)
- White wire shelves
- Black wire shelves
- Chrome plated wire shelves
- Stainless steel mezzanine shelves

OPTIONAL FEATURES/ACCESSORIES

Upcharge and lead times may apply.

- Custom exterior colors (contact factory for details)
- Chocolate/Wine model available
- Glass shelves
- Frosted glass shelves
- Ratchet lock
- Electrical Receptacle
- Exterior top scale shelf
- Exterior small top service shelf
- Exterior medium top service shelf
- Exterior large top service shelf
- External front shelf kit (only available in black)
- External rear service shelf kit (only available in black)

TGM MODEL NUMBER NOMENCLATURE SYSTEM

True Glass Merchandiser

Size: (36, 48, 59, 77)

END TYPE

COLOR

Left Position / Right Position

Exterior / Interior

TGM - R - 77 - SC / SC - B - W

Type:
R - Refrigerator
DZ - Dual Zone
DC - Dry Case
CW - Chocolate/Wine

Side Type:
SC - Solid Colored End

Color:
B - Black
W - White
S - Stainless Steel

PLAN VIEW

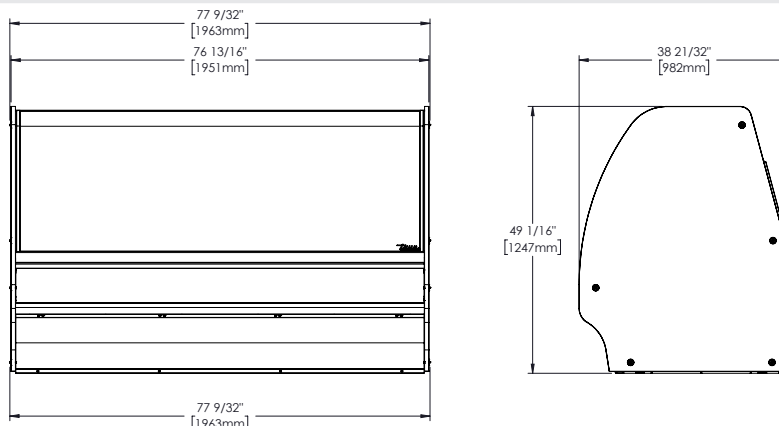

METRIC DIMENSIONS ROUNDED UP TO THE NEAREST WHOLE MILLIMETER

SPECIFICATIONS SUBJECT TO CHANGE WITHOUT NOTICE

	Elevation	Right	Plan	3D	Back

Models TDM-DC-77-GE/GE-B-W TDM-DC-77-GE/GE-W-W TDM-DC-77-GE/GE-S-W TDM-DC-77-GE/GE-S-S

True Display Merchandiser

Curved Glass, Glass End Dry Case



TDM-DC-77-GE/GE-B-W



TDM-DC-77-GE/GE-W-W



TDM-DC-77-GE/GE-S-S



TDM-DC-77-GE/GE-B-B (optional black interior)

FEATURES

- ▶ True's "dry" display case combines efficient, high volume merchandising with an elegant curved glass front for sophisticated presentation of high end desserts and pastries.
- ▶ Cabinet is NSF/ANSI Standard 2 compliant to hold open food product.
- ▶ Two (2) rear sliding glass doors for back access.
- ▶ Exterior - powder coated FDA black rounded front and back, black aluminum aesthetic side and front panels. Color options available (upcharge may apply) - white or stainless. Curved glass front and side glass panels.
- ▶ Interior - powder coated FDA white over CRS material. Color options available (upcharge may apply) - black or stainless.
- ▶ Three (3) tiered levels of adjustable wire cantilever shelves that match cabinet interior color. Chrome plated wire shelves standard on stainless units.
- ▶ Front glass swings Up for easy cleaning access.
- ▶ LED interior lighting provides more even lighting throughout the cabinet. Safety shielded.

STANDARD OPTIONS

Exterior Color	Black, White, or Stainless Steel
Interior Color	Black, White, or Stainless Steel
Glass End (GE)	Clear Glass Interior/Clear Glass Exterior with Black Trim
Shelving	White, Black, Chrome, or Mezzanine

ROUGH-IN DATA

Specifications subject to change without notice. Chart dimensions rounded up to the nearest 1/8" (millimeters rounded up to next whole number).

Model	Doors	Shelves	Cabinet Dimensions (inches) (mm)			Voltage	Amps	NEMA Config.	Cord Length (total ft.) (total m)	Crated Weight White/Black Model (lbs.) (kg)	Crated Weight Stainless Model (lbs.) (kg)
			W	D	H						
TDM-DC-77-GE/GE-Δ-Δ	2	3	77¼ 1963	39 991	49½ 1248	115/60/1 230-240/50/1	7.0 0.3	5-15P ▲	8 2.44	685 311	830 377

Δ Represents Exterior/Interior (B-black, W-White, S-Stainless)

▲ Plug type varies by country.

Models:	
TDM-DC-77-GE/GE-B-W	TDM-DC-77-GE/GE-W-W
TDM-DC-77-GE/GE-S-W	TDM-DC-77-GE/GE-S-S

True Display Merchandiser: Curved Glass, Glass End Dry Case



STANDARD FEATURES

DESIGN

- True's "dry" display case combines efficient, high volume merchandising with an elegant curved glass front for sophisticated presentation of high end desserts and pastries.
- Designed to provide an attractive companion to our TDM-R "refrigerated" display merchandiser. Please note: If units are banked together, because of side panel, a 1/2" gap will remain between units.

CABINET CONSTRUCTION

- Exterior - powder coated FDA black rounded front and back, black aluminum aesthetic side and front panels. Color options available (upcharge may apply) - white or stainless.
- Curved glass front and side glass panels.
- Interior - powder coated FDA white over CRS material. Color options available (upcharge may apply) - black or stainless.
- Insulation - entire cabinet structure is foamed-in-place using a high density, polyurethane insulation that has zero ozone depletion potential (ODP) and 0.02 global warming potential (GWP).
- Welded, heavy duty steel frame rail, black powder coated for corrosion protection.
- Frame rail fitted with leg levelers.

CURVED FRONT DISPLAY GLASS

- Curved glass front and side panels are single pane tempered glass. Front glass opens from closed to fully open to provide extra large viewing area to maximize product presentation while allowing full frontal access.

REAR DOORS

- Two (2) rear sliding glass doors for back access.
- Each door fitted with 12" (305 mm) long aluminum handle.
- Sliding doors ride on stainless steel V-channel with stainless steel bearings. Doors fit within plastic channel frame.

SHELVING

- Three (3) adjustable heavy duty PVC coated wire shelves standard.
- Each shelf supports a maximum weight of 150 lbs. (69 kg).

PAN CAPACITY

- Cabinet holds eight (8) 18"L x 26"D (458 mm x 661 mm) display pans and twelve (12) 12"L x 18"D (305 mm x 458 mm) display pans. Pans supplied by others.

LIGHTING

- LED interior lighting, two (2) clips underneath shelf to keep wires in place. Safety shielded.

MODEL FEATURES

- Front glass swings Up for easy cleaning access.
- NSF/ANSI Standard 2 compliant for open food product.

ELECTRICAL

- Unit completely pre-wired at factory and ready for final connection to a 115/60/1 phase, 15 amp dedicated outlet. Cord and plug set included.



OPTIONAL FEATURES/ACCESSORIES
Upcharge and lead times may apply.

- 230 - 240V / 50 Hz.
- White exterior
- Stainless steel exterior
- Custom exterior colors (contact factory for details)
- Black interior
- Stainless steel interior
- Black wire shelves
- Chrome plated wire shelves
- Stainless mezzanine shelves

TDM MODEL NUMBER NOMENCLATURE SYSTEM

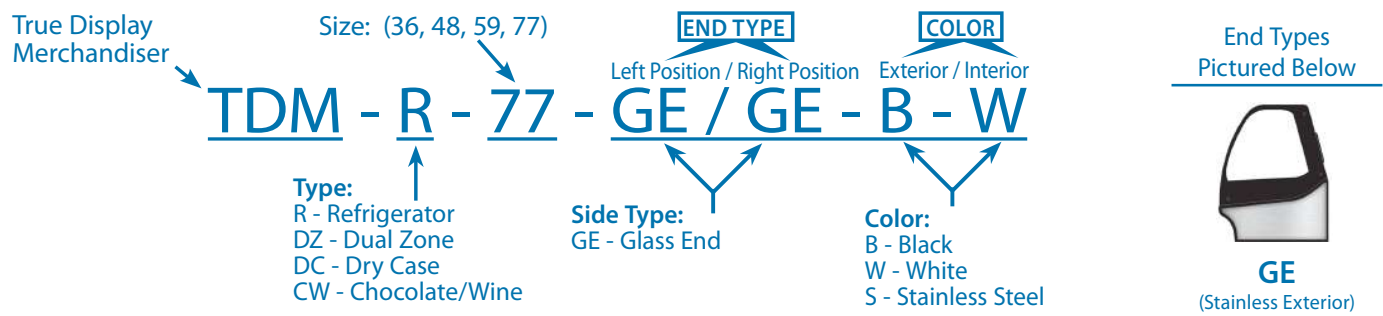

PLAN VIEW

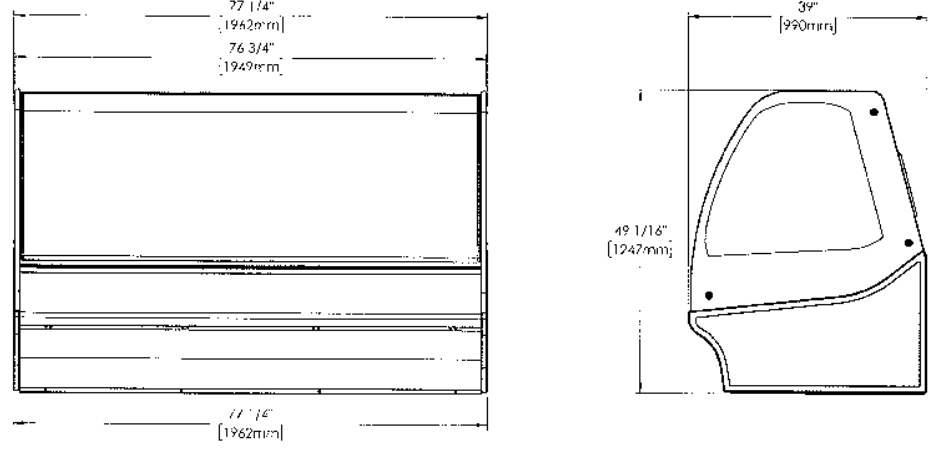

METRIC DIMENSIONS ROUNDED UP TO THE NEAREST WHOLE MILLIMETER
SPECIFICATIONS SUBJECT TO CHANGE WITHOUT NOTICE

	Elevation	Right	Plan	3D	Back

Models TDM-R-77-GE/GE-B-W TDM-R-77-GE/GE-W-W TDM-R-77-GE/GE-S-W TDM-R-77-GE/GE-S-S

True Display Merchandiser Curved Glass, Glass End Refrigerator



TDM-R-77-GE/GE-B-W



TDM-R-77-GE/GE-W-W



TDM-R-77-GE/GE-S-S



TDM-R-77-GE/GE-B-B (optional black interior)

FEATURES

- ▶ True's refrigerated display merchandisers combine efficient, high volume merchandising and exceptional refrigeration with an elegant curved glass front for sophisticated presentation of high end desserts and pastries.
- ▶ Factory engineered, self-contained, capillary tube system using environmentally friendly R290 hydrocarbon refrigerant that has zero (0) ozone depletion potential (ODP), & 0.02 global warming potential (GWP).
- ▶ High capacity, factory balanced refrigeration system. Standard temperature range maintains cabinet temperatures of 33°F to 41°F (.5°C to 5°C), ideally suited for refrigerated bakery and cold deli products.
- ▶ Cabinet is NSF/ANSI Standard 7 compliant to hold open food product.
- ▶ Two (2) rear sliding glass doors for back access.
- ▶ Exterior - powder coated FDA black rounded front and back, black aluminum aesthetic side and front panels. Color options available (upcharge may apply) - white or stainless. Curved glass front and side glass panels.
- ▶ Interior - powder coated FDA white over CRS material. Color options available (upcharge may apply) - black or stainless.
- ▶ Three (3) tiered levels of adjustable wire cantilever shelves that match cabinet interior color. Chrome plated wire shelves standard on stainless units.
- ▶ Front glass swings Up for easy cleaning access.
- ▶ LED interior lighting provides more even lighting throughout the cabinet. Safety shielded.

STANDARD OPTIONS

Exterior Color	Black, White, or Stainless Steel
Interior Color	Black, White, or Stainless Steel
Glass End (GE)	Clear Glass Interior/Clear Glass Exterior with Black Trim
Shelving	White, Black, Chrome, or Mezzanine

ROUGH-IN DATA

Specifications subject to change without notice. Chart dimensions rounded up to the nearest 1/8" (millimeters rounded up to next whole number).

Model	Doors	Shelves	Cabinet Dimensions (inches) (mm)				HP	Voltage	Amps	NEMA Config.	Cord Length (total ft.) (total m)	Crated Weight White/Black Model (lbs.) (kg)	Crated Weight Stainless Model (lbs.) (kg)
			W	D	H	HP							
TDM-R-77-GE/GE-Δ/Δ	2	3	77¼ 1963	39 991	49⅞ 1248	½ ½	115/60/1 230-240/50/1	12.0 3.6	5-15P ▲	8 2.44	785 356	TBD TBD	

Δ Represents Exterior/Interior (B-black, W-White, S-Stainless)

▲ Plug type varies by country.

Models:		True Display Merchandiser:	
TDM-R-77-GE/GE-B/W	TDM-R-77-GE/GE-W-W	Curved Glass, Glass End Refrigerator	
TDM-R-77-GE/GE-S-W	TDM-R-77-GE/GE-S-S		

STANDARD FEATURES

DESIGN

- True's refrigerated display case combines efficient, high volume merchandising and exceptional refrigeration with an elegant curved glass front for sophisticated presentation of high end deli, desserts and pastries.
- Designed to provide an attractive companion to our TDM-DC "dry case" display merchandiser. Please note: If units are banked together, because of side panel, a 1/2" gap will remain between units.

REFRIGERATION SYSTEM

- Factory engineered, self-contained, capillary tube system using environmentally friendly R290 hydrocarbon refrigerant that has zero (0) ozone depletion potential (ODP), & 0.02 global warming potential (GWP).
- True's self-cleaning RCU technology eliminates the need to clean the condenser coil, reduces energy consumption and helps maintain the coldest temperatures and freshest product.
- High capacity, factory balanced refrigeration system that has two (2) temperature range options. Standard temperature range maintains cabinet temperatures of 33°F to 41°F (.5°C to 5°C), ideally suited for refrigerated bakery and cold deli products. Optional temperature range maintains cabinet temperatures of 42°F to 65°F (5.5°C to 18.3°C), ideally suited for chocolate & wine options.
- Pull Out Condensing unit slides out for easy cleaning and maintenance.

CABINET CONSTRUCTION

- Exterior - powder coated FDA black rounded front and back, black aluminum aesthetic side and front panels. Color options available (upcharge may apply) - white or stainless.
- Curved glass front and side glass panels.

- Interior - powder coated FDA white over CRS material. Color options available (upcharge may apply) - black or stainless.
- Insulation - entire cabinet structure is foamed-in-place using a high density, polyurethane insulation that has zero ozone depletion potential (ODP) and zero global warming potential (GWP).
- Welded, heavy duty steel frame rail, black powder coated for corrosion protection.
- Frame rail fitted with leg levelers.

CURVED FRONT DISPLAY GLASS

- Curved glass front and side panels are single pane tempered glass. Front glass opens from closed to fully open to provide extra large viewing area to maximize product presentation while allowing full frontal access.

REAR DOORS

- Two (2) rear sliding glass doors for back access.
- Each door fitted with 12" (305 mm) long aluminum handle.
- Sliding doors ride on stainless steel V-channel with stainless steel bearings. Doors fit within plastic channel frame.

SHELVING

- Three (3) adjustable heavy duty PVC coated wire shelves standard.
- Each shelf supports a maximum weight of 150 lbs. (69 kg).

PAN CAPACITY

- Cabinet holds eight (8) 18"L x 26"D (458 mm x 661 mm) display pans and twelve (12) 12"L x 18"D (305 mm x 458 mm) display pans. Pans supplied by others.

LIGHTING

- LED interior lighting, two (2) clips underneath shelf to keep wires in place. Safety shielded.

MODEL FEATURES

- Evaporator is epoxy coated to eliminate the potential of corrosion.
- Front glass swings Up for easy cleaning access.
- Pull out condensing unit slides out for easy cleaning and maintenance.
- Electronic temperature control.
- NSF/ANSI Standard 7 compliant for open food product. Tested and certified for performance at NSF Type II: 80°F (27°C) and 55% relative humidity.

ELECTRICAL

- Unit completely pre-wired at factory and ready for final connection to a 115/60/1 phase, 15 amp dedicated outlet. Cord and plug set included.



OPTIONAL FEATURES/ACCESSORIES

- Upcharge and lead times may apply.
- 230 - 240V / 50 Hz.
 - White exterior
 - Stainless steel exterior
 - Custom exterior colors (contact factory for details)
 - Black interior
 - Stainless steel interior
 - Black wire shelves
 - Chrome plated wire shelves
 - Stainless mezzanine shelves

TDM MODEL NUMBER NOMENCLATURE SYSTEM

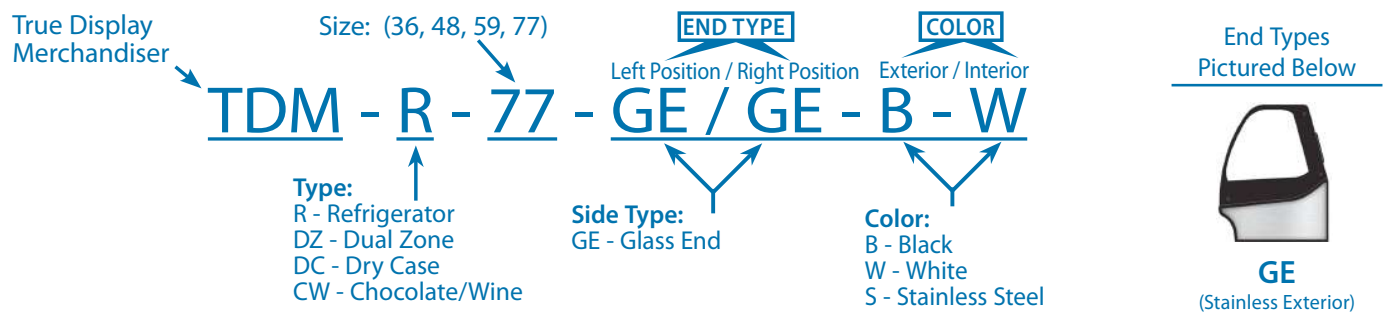

PLAN VIEW

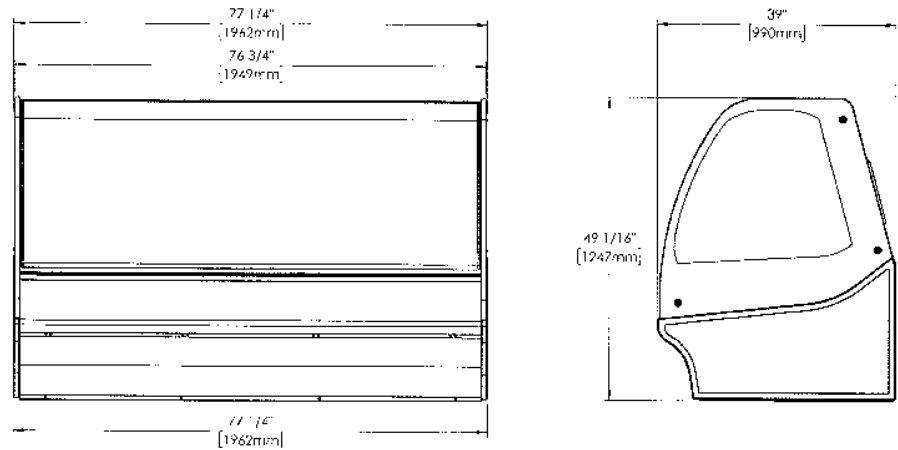

METRIC DIMENSIONS ROUNDED UP TO THE NEAREST WHOLE MILLIMETER
 SPECIFICATIONS SUBJECT TO CHANGE WITHOUT NOTICE

	Elevation	Right	Plan	3D	Back

Models TDM-DZ-77-GE/GE-B-W TDM-DZ-77-GE/GE-W-W TDM-DZ-77-GE/GE-S-W TDM-DZ-77-GE/GE-S-S

True Display Merchandiser Curved Glass, Glass End Dual Zone



TDM-DZ-77-GE/GE-B-W



TDM-DZ-77-GE/GE-W-W



TDM-DZ-77-GE/GE-S-S



TDM-DZ-77-GE/GE-B-B (optional black interior)

FEATURES

- ▶ True's refrigerated display merchandisers combine efficient, high volume merchandising and exceptional refrigeration with an elegant curved glass front for sophisticated presentation of high end desserts and pastries.
- ▶ Factory engineered, self-contained, capillary tube system using environmentally friendly R290 hydrocarbon refrigerant that has zero (0) ozone depletion potential (ODP), & 0.02 global warming potential (GWP).
- ▶ Refrigerated section features high capacity, factory balanced refrigeration system. Standard temperature range maintains cabinet temperatures of 33°F to 41°F (.5°C to 5°C), ideally suited for refrigerated bakery and cold deli products.
- ▶ Cabinet is NSF/ANSI Standard 7 compliant to hold open food product.
- ▶ Two (2) rear sliding glass doors for back access.
- ▶ Exterior - powder coated FDA black rounded front and back, black aluminum aesthetic side and front panels. Color options available (upcharge may apply) - white or stainless. Curved glass front and side glass panels.
- ▶ Interior - powder coated FDA white over CRS material. Color options available (upcharge may apply) - black or stainless.
- ▶ Six (6) tiered levels of adjustable wire cantilever shelves that match cabinet interior color. Chrome plated wire shelves standard on stainless units.
- ▶ Front glass swings Up for easy cleaning access.
- ▶ LED interior lighting provides more even lighting throughout the cabinet. Safety shielded.

STANDARD OPTIONS

Exterior Color	Black, White, or Stainless Steel
Interior Color	Black, White, or Stainless Steel
Glass End (GE)	Clear Glass Interior/Clear Glass Exterior with Black Trim
Shelving	White, Black, Chrome, or Mezzanine

ROUGH-IN DATA

Specifications subject to change without notice. Chart dimensions rounded up to the nearest 1/8" (millimeters rounded up to next whole number).

Model	Doors	Shelves	Cabinet Dimensions (inches) (mm)				HP	Voltage	Amps	NEMA Config.	Cord Length (total ft.) (total m)	Crated Weight White/Black Model (lbs.) (kg)	Crated Weight Stainless Model (lbs.) (kg)
			W	D	H	HP							
TDM-DZ-77-GE/GE-ΔΔ	2	6	77¼ 1963	39 991	49⅞ 1248	¼ ¼	115/60/1 230-240/50/1	10.0 2.0	5-15P ▲	8 2.44	795 361	TBD TBD	

Δ Represents Exterior/Interior (B-black, W-White, S-Stainless)

▲ Plug type varies by country.

Models:	
TDM-DZ-77-GE/GE-B-W	TDM-DZ-77-GE/GE-W-W
TDM-DZ-77-GE/GE-S-W	TDM-DZ-77-GE/GE-S-S

True Display Merchandiser: Curved Glass, Glass End Dual Zone



STANDARD FEATURES

DESIGN

- True's combination "refrigerated" and "dry" display case combines efficient, high volume merchandising and exceptional refrigeration with an elegant curved glass front for sophisticated presentation of high end deli, desserts and pastries.
- Please note: If units are banked together, because of side panel, a 1/2" gap will remain between units.

REFRIGERATION SYSTEM

- Factory engineered, self-contained, capillary tube system using environmentally friendly R290 hydrocarbon refrigerant that has zero (0) ozone depletion potential (ODP), & 0.02 global warming potential (GWP).
- True's self-cleaning RCU technology eliminates the need to clean the condenser coil, reduces energy consumption and helps maintain the coldest temperatures and freshest product.
- High capacity, factory balanced refrigeration system that has two (2) temperature range options in refrigerated section. Standard temperature range maintains cabinet temperatures of 33°F to 41°F (.5°C to 5°C), ideally suited for refrigerated bakery and cold deli products. Optional temperature range maintains cabinet temperatures of 42°F to 65°F (5.5°C to 18.3°C), ideally suited for chocolate & wine options.
- Pull Out Condensing unit slides out for easy cleaning and maintenance.

CABINET CONSTRUCTION

- Exterior - powder coated FDA black rounded front and back, black aluminum aesthetic side and front panels. Color options available (upcharge may apply) - white or stainless.
- Curved glass front and side glass panels.

- Interior - powder coated FDA white over CRS material. Color options available (upcharge may apply) - black or stainless.
- Insulation - entire cabinet structure is foamed-in-place using a high density, polyurethane insulation that has zero ozone depletion potential (ODP) and zero global warming potential (GWP).
- Welded, heavy duty steel frame rail, black powder coated for corrosion protection.
- Frame rail fitted with leg levelers.

CURVED FRONT DISPLAY GLASS

- Curved glass front and side panels are single pane tempered glass. Front glass opens from closed to fully open to provide extra large viewing area to maximize product presentation while allowing full frontal access.

REAR DOORS

- Two (2) rear sliding glass doors for back access.
- Each door fitted with 12" (305 mm) long aluminum handle.
- Sliding doors ride on stainless steel V-channel with stainless steel bearings. Doors fit within plastic channel frame.

SHELVING

- Six (6) adjustable heavy duty PVC coated wire shelves standard.
- Each shelf supports a maximum weight of 150 lbs. (69 kg).

PAN CAPACITY

- Cabinet holds eight (8) 18"L x 26"D (458 mm x 661 mm) display pans and twelve (12) 12"L x 18"D (305 mm x 458 mm) display pans. Pans supplied by others.

LIGHTING

- LED interior lighting, two (2) clips underneath shelf to keep wires in place. Safety shielded.

MODEL FEATURES

- Refrigerator evaporator is epoxy coated to eliminate the potential of corrosion.
- Front glass swings Up for easy cleaning access.
- Pull out condensing unit slides out for easy cleaning and maintenance.
- Electronic temperature control.
- NSF/ANSI Standard 7 compliant for open food product. Tested and certified for performance at NSF Type II: 80°F (27°C) and 55% relative humidity.

ELECTRICAL

- Unit completely pre-wired at factory and ready for final connection to a 115/60/1 phase, 15 amp dedicated outlet. Cord and plug set included.



OPTIONAL FEATURES/ACCESSORIES

Upcharge and lead times may apply.

- 230 - 240V / 50 Hz.
- White exterior
- Stainless steel exterior
- Custom exterior colors (contact factory for details)
- Black interior
- Stainless steel interior
- Black wire shelves
- Chrome plated wire shelves
- Stainless mezzanine shelves

TDM MODEL NUMBER NOMENCLATURE SYSTEM

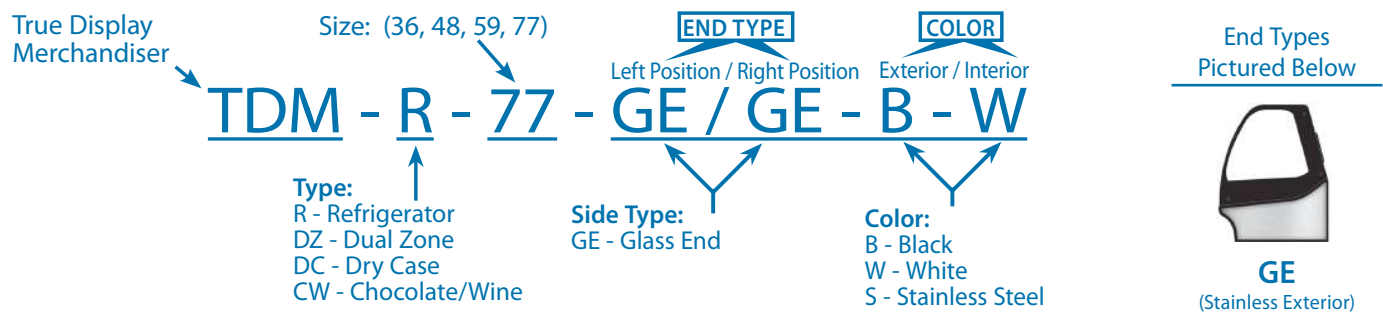

PLAN VIEW

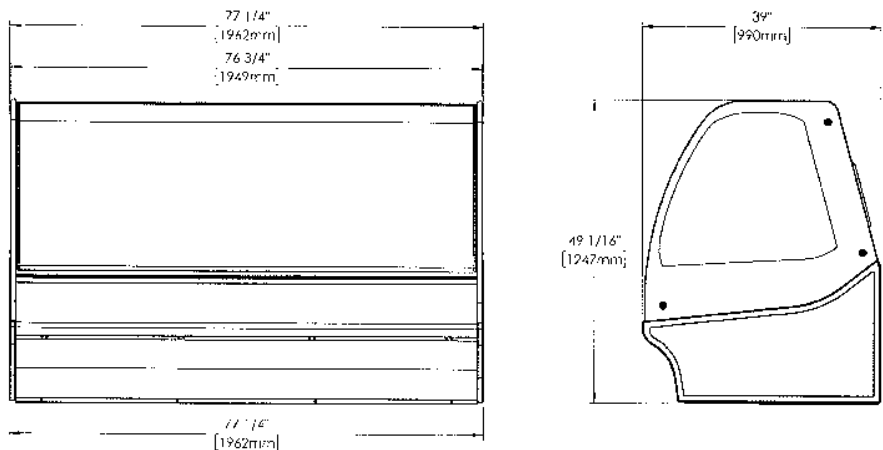

METRIC DIMENSIONS ROUNDED UP TO THE NEAREST WHOLE MILLIMETER
SPECIFICATIONS SUBJECT TO CHANGE WITHOUT NOTICE

	Elevation	Right	Plan	3D	Back

По вопросам продаж и поддержки обращайтесь:

Алматы (7273)495-231	Калининград (4012)72-03-81	Омск (3812)21-46-40	Сыктывкар (8212)25-95-17
Ангарск (3955)60-70-56	Калуга (4842)92-23-67	Орел (4862)44-53-42	Тамбов (4752)50-40-97
Архангельск (8182)63-90-72	Кемерово (3842)65-04-62	Оренбург (3532)37-68-04	Тверь (4822)63-31-35
Астрахань (8512)99-46-04	Киров (8332)68-02-04	Пенза (8412)22-31-16	Тольятти (8482)63-91-07
Барнаул (3852)73-04-60	Коломна (4966)23-41-49	Петрозаводск (8142)55-98-37	Томск (3822)98-41-53
Белгород (4722)40-23-64	Кострома (4942)77-07-48	Псков (8112)59-10-37	Тула (4872)33-79-87
Благовещенск (4162)22-76-07	Краснодар (861)203-40-90	Пермь (342)205-81-47	Тюмень (3452)66-21-18
Брянск (4832)59-03-52	Красноярск (391)204-63-61	Ростов-на-Дону (863)308-18-15	Ульяновск (8422)24-23-59
Владивосток (423)249-28-31	Курск (4712)77-13-04	Рязань (4912)46-61-64	Улан-Удэ (3012)59-97-51
Владикавказ (8672)28-90-48	Курган (3522)50-90-47	Самара (846)206-03-16	Уфа (347)229-48-12
Владимир (4922)49-43-18	Липецк (4742)52-20-81	Саранск (8342)22-96-24	Хабаровск (4212)92-98-04
Волгоград (844)278-03-48	Магнитогорск (3519)55-03-13	Санкт-Петербург (812)309-46-40	Чебоксары (8352)28-53-07
Вологда (8172)26-41-59	Москва (495)268-04-70	Саратов (845)249-38-78	Челябинск (351)202-03-61
Воронеж (473)204-51-73	Мурманск (8152)59-64-93	Севастополь (8692)22-31-93	Череповец (8202)49-02-64
Екатеринбург (343)384-55-89	Набережные Челны (8552)20-53-41	Симферополь (3652)67-13-56	Чита (3022)38-34-83
Иваново (4932)77-34-06	Нижний Новгород (831)429-08-12	Смоленск (4812)29-41-54	Якутск (4112)23-90-97
Ижевск (3412)26-03-58	Новокузнецк (3843)20-46-81	Сочи (862)225-72-31	Ярославль (4852)69-52-93
Иркутск (395)279-98-46	Ноябрьск (3496)41-32-12	Ставрополь (8652)20-65-13	
Казань (843)206-01-48	Новосибирск (383)227-86-73	Сургут (3462)77-98-35	
Россия +7(495)268-04-70	Киргизия +996(312)-96-26-47	Казахстан +7(7172)727-132	